

## 50 $\mu$ H Line Impedance Stabilisation Network

### 1 Introduction

The TBL50100-1B is a single path 50 $\mu$ H (+5  $\Omega$ ) // 50  $\Omega$  LISN for conducted emission measurements of DC or AC-powered electronic equipment. It is designed according to CISPR 16-1-2 and MIL-STD-461G standards and characterized in the frequency range of 10 kHz to 100 MHz.

Setting a high current jumper shorts the 5 Ohm resistor and configures it as 50 $\Omega$  // 50 $\mu$ H LISN according to CISPR 16-1-2. Removing the jumper configures the LISN to (50 $\mu$ H + 5  $\Omega$ ) // 50  $\Omega$  for MIL-STD application. The LISN is characterized from 10 kHz to 100 MHz.

Combining two LISN with the Tekbox LISN Mate enables separate measurement of common mode and differential mode noise. EUTs with 3 phase supply require three or four pieces of TBL50100-1B, depending on whether the product is supplied in delta or star configuration.

An exposed bottom panel enables convenient ground plane connection. The unit comes equipped with a N-male to N-male RG223 cable.



TBL50100-1B EUT Side



TBL50100-1B Source Side

# 50 $\mu$ H Line Impedance Stabilisation Network

## 2 Specification

**LISN type:** single path V-AMN, configurable (jumper) as 50 $\Omega$ /50 $\mu$ H+5  $\Omega$  or 50 $\Omega$ /50 $\mu$ H; no 250 $\mu$ H pre-filter

**Characterized Frequency range:** 10 kHz – 100 MHz

**DC Resistance:** < 20 m $\Omega$

**Maximum current:** 82 A continuous, 100A for 15 minutes; see heat up characteristics plot

**Maximum operating voltage range:** 0 – 500V DC; 0 - 270V AC (50/60 Hz), 0 – 120V AC (400 Hz)

**EUT connector:** binding post M8, 4mm center hole, 100A, 1kV, Schützinger POL 102 L / RT

**SOURCE connector:** binding post M8, 4mm center hole, 100A, 1kV, Schützinger POL 102 L / RT

**Earth:** 8mm Earth stud with wing-nut, exposed stainless steel bottom panel with mounting slots and countersunk hole for 4mm screw

**RF connector:** N-Female

**Jumper:** Harwin D3087-98

**Dimensions:** W x H x L; 230 mm x 230 mm x 350 mm;

**Weight:** 5.3 kg

### 2.1 Conformity

The TBL50100-1B is compliant with CISPR 16-1-2 and MIL-STD-461G.

In line with the CISPR 16-1-2 / MIL-STD-461G standard compliant design and setup specification, the LISN exhibits high ground leakage currents and non-standard isolation and consequently cannot meet the safety requirements of EN 61010-1.

Furthermore CISPR 16-1-2 specifies high capacitance values for the capacitors from Line / + to Ground. These capacitance values are not commercially available in Y2 rating and are implemented using AC rated capacitors with suitable voltage rating.

In order to prevent the danger of lethal electric shock, the operator is responsible for ensuring protective measures in line with IEC 60364-4-41 and IEC 60364-5-54 and to follow all safety related information of this manual.

### 2.2 Safety

To ensure safe operations, the user must adhere to all safety-related information in this manual. All metal parts of the housing are connected to the earth pins of the Source and DUT sockets. Before connecting any other conductor to the LISN, connect the Earth brackets to protective Earth.

Protective Earth must not be disconnected from the Earth brackets unless all other wiring has been disconnected first. Special care must be taken to avoid connecting AC - line or VDC+ to the EARTH pin of the SOURCE connector by mistake.

When operating the LISN with alternating current, use an isolation transformer.

While the source connector is under voltage, do not connect or disconnect it.

The TBL50100-1B shall be operated by qualified laboratory staff only.

## 50 $\mu$ H Line Impedance Stabilisation Network

### 2.3 Warning

#### **Spectrum Analyzer / Measurement Receiver protection:**

The TBL50100-1B LISN does not contain any protective elements in the RF path. Use an external attenuator and/or limiter, if your EUT may produce harmful transients or high RF noise levels, in order to protect the spectrum analyser / measurement receiver input. If using without transient limiter and testing AC supplied products, it is highly recommended to protect the input of the connected analyzer with Tekbox highpass filters or to insert the internal highpass jumper.

#### **Safety:**

Operating an AC LISN involves dealing with potentially lethal voltages and high ground leakage currents. The LISN shall only be operated by qualified staff.



Read this manual carefully and be sure to understand the operation of the LISN. Make sure that the conducted noise pre – compliance test equipment is set up correctly and that the necessary earth connections are reliably bonded to avoid the risk of lethal electric shocks. The ground brackets must be securely connected to the protective earth conductor available on site, before making any other electrical connection. This connection must not be separated, until the mains supply is disconnected from the LISN setup.

When connecting the LISN to AC mains voltage, always use an isolation transformer.

Take precautions, such as validating the signal amplitude at the RF output prior to connecting a spectrum analyzer or using attenuators and/or limiters to prevent damage to your test receiver or spectrum analyzer.

Do not carry out any modifications or manipulations of the TBL50100-1B.

Avoid touching the housing, when operating the LISN at maximum current over extended time. The housing temperature may rise up to 45°C. Turn off the EUT after measurements to avoid unnecessary dissipation.

The LISN housing is connected to the negative / ground SOURCE and EUT pin of the terminal block and the ground of the RF connector. Inadvertently connecting the positive voltage to the ground pin will expose you to the risk of electric shock. The maximum source voltage rating with respect to component ratings is 250V.

## 50µH Line Impedance Stabilisation Network

### 3 Principle schematic

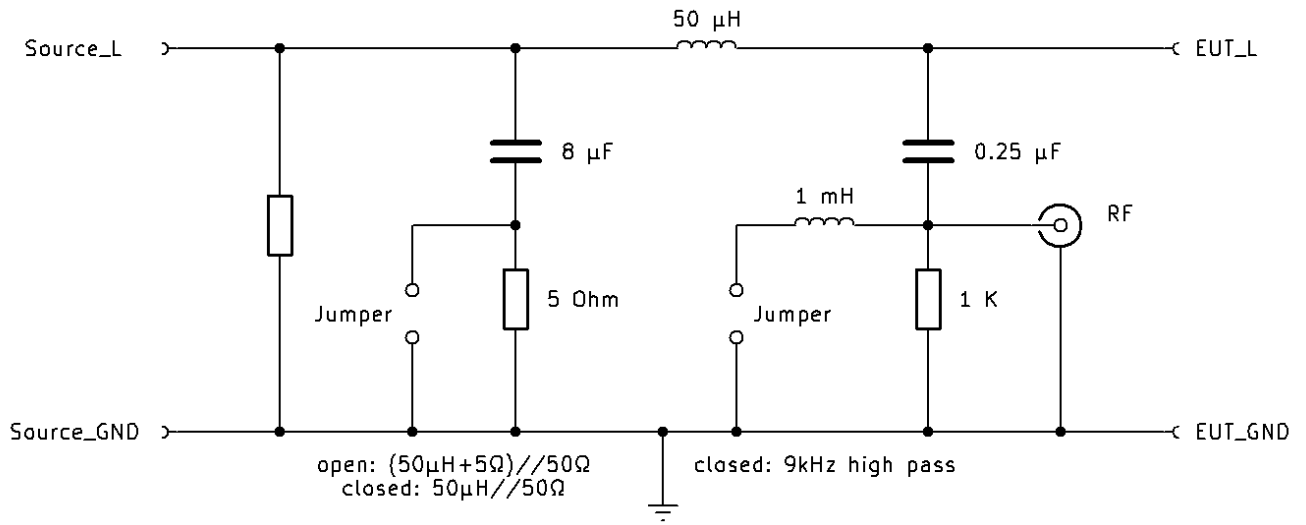

Picture 1: principle schematic

### 4 Impedance

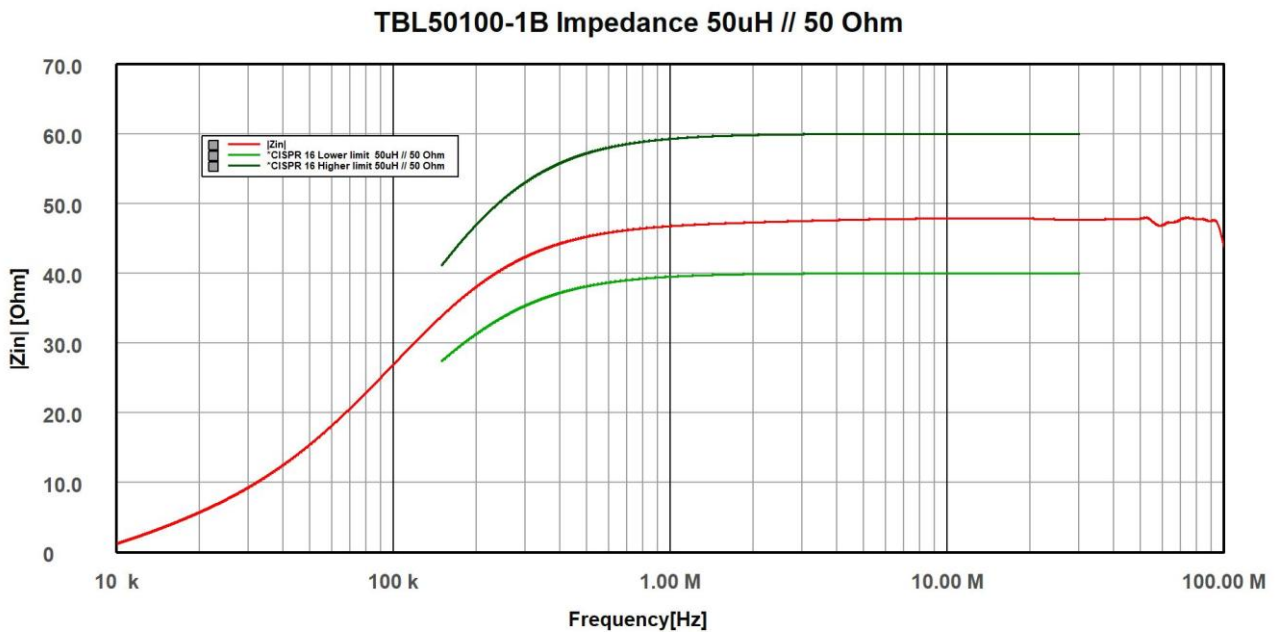

Picture 2: LISN impedance, 50Ω//50µH CISPR 16

## 50µH Line Impedance Stabilisation Network

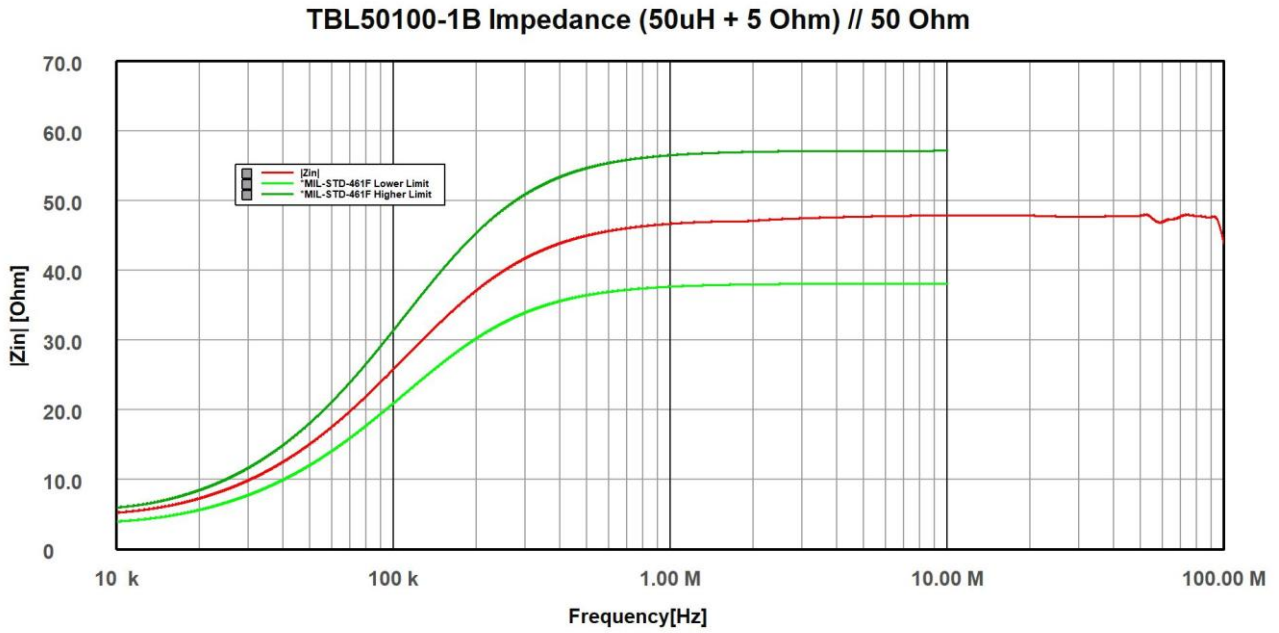

Picture 3: LISN impedance, (50µH + 5Ω) // 50 Ω MIL-STD

## 5 Phase

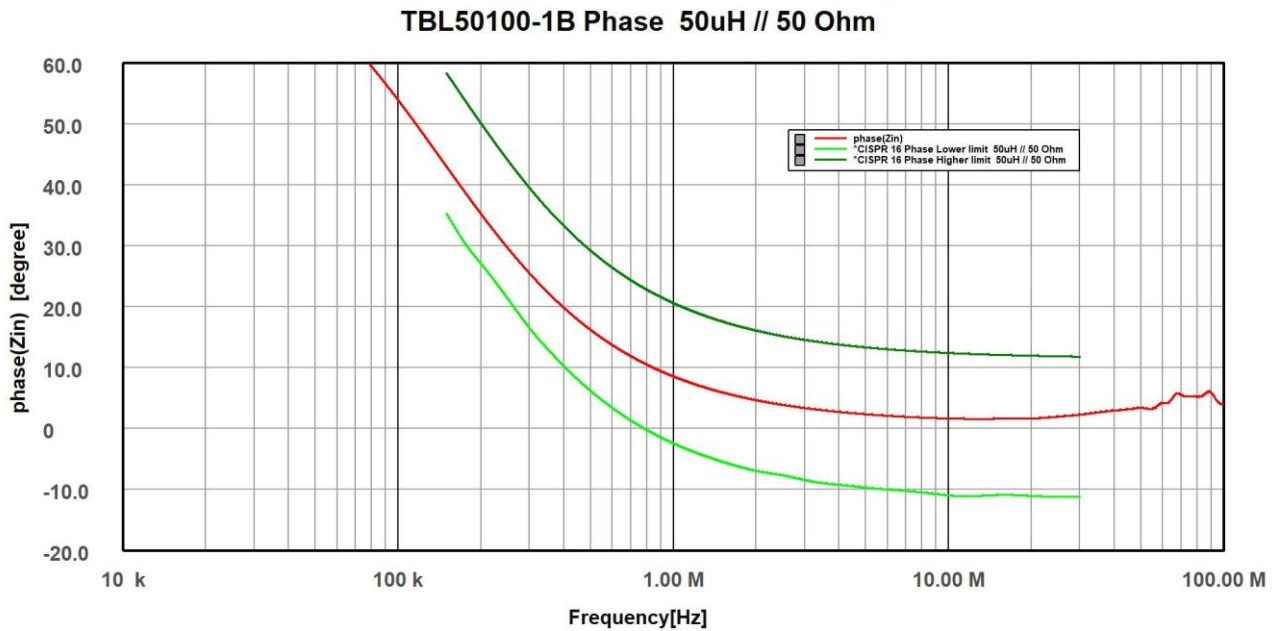

Picture 4: LISN phase, 50Ω // 50µH CISPR 16

## 50µH Line Impedance Stabilisation Network

### 6 Isolation

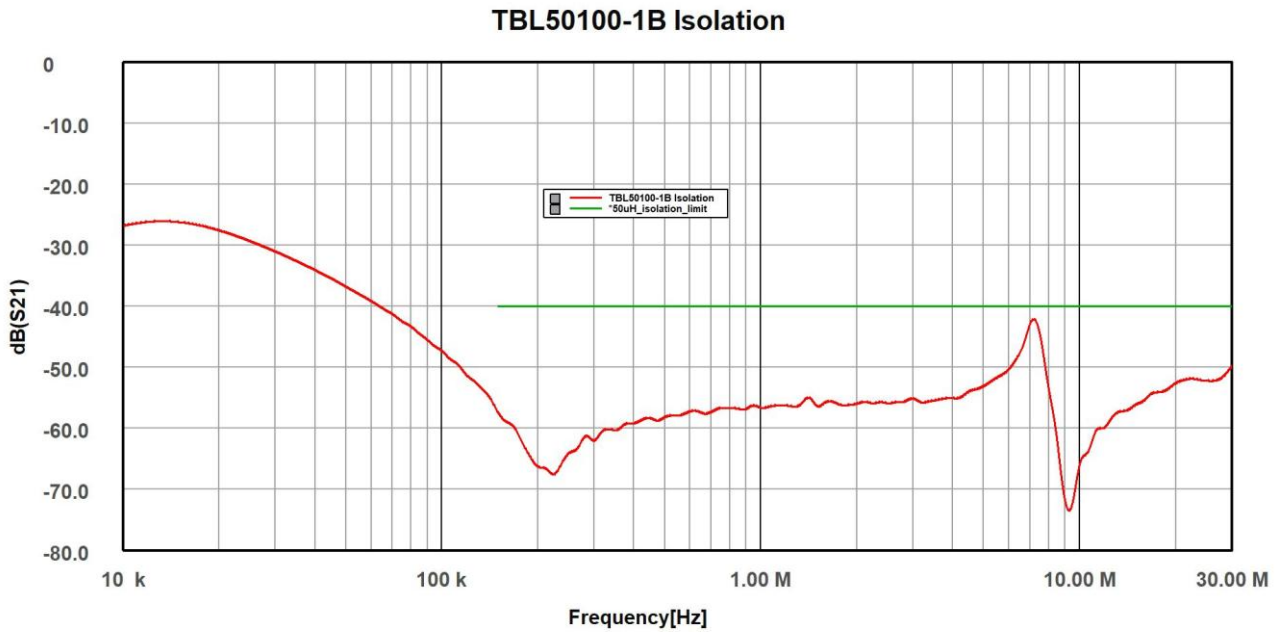

Picture 5: LISN Isolation, Source to RF out, 50Ω // 50µH CISPR 16

The isolation is measured between SOURCE terminal and RF port, with the EUT port terminated with 50 Ohm.

### 7 Thermal characteristics

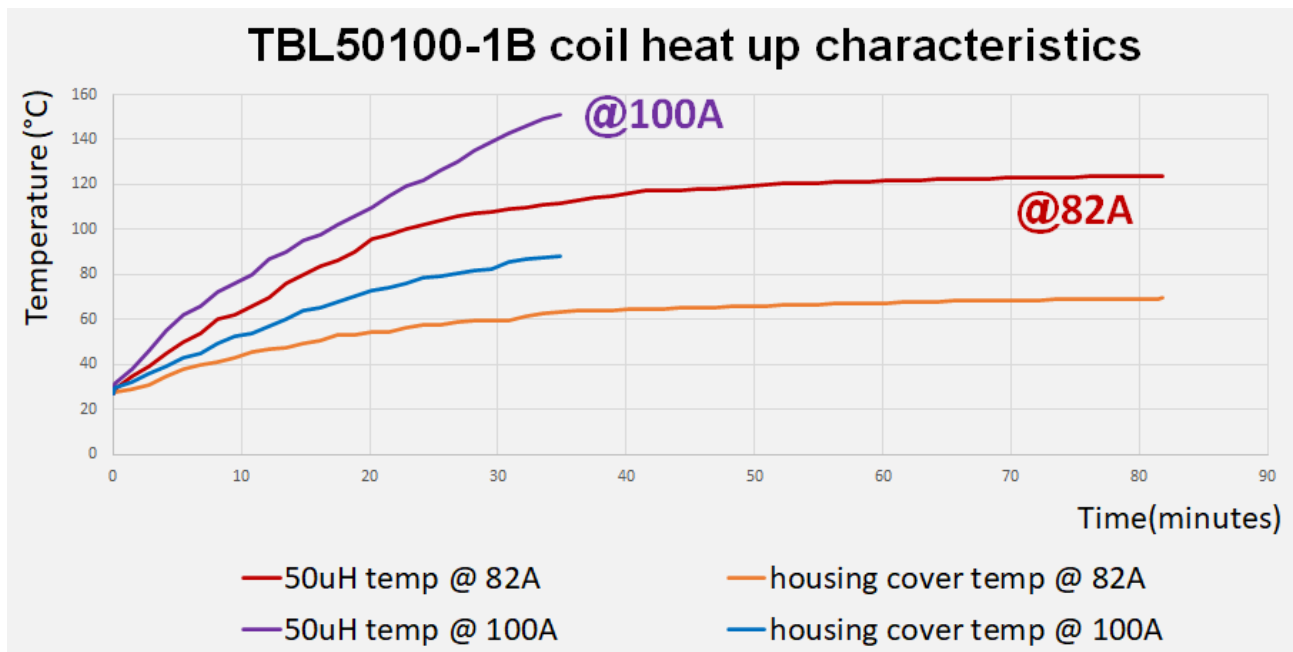

Picture 6: Coil and housing temperature

## 50µH Line Impedance Stabilisation Network

### 8 Calibration data according to CISPR 16 -1-2 Annex A8

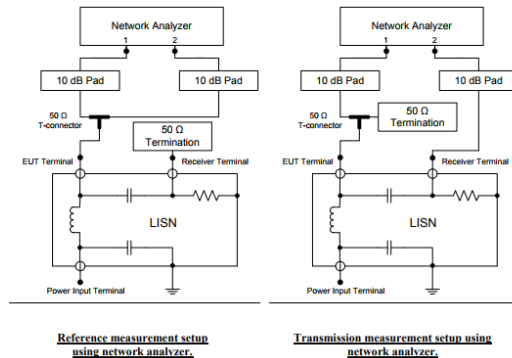

Picture 7: Calibration set up according to CISPR 16-1-2 Annex A.8.

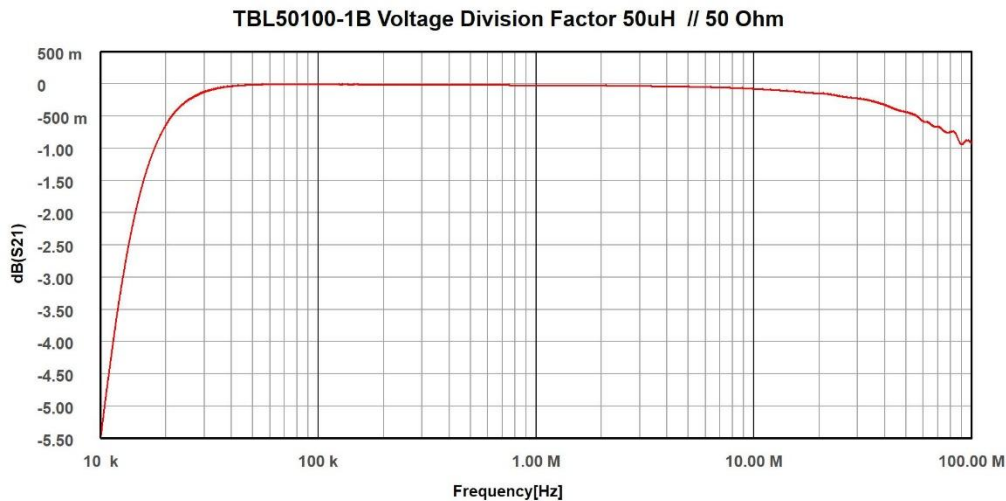

Picture 8: Voltage division ratio EUT terminals to RF connector, 50Ω // 50µH, CISPR 16

Frequency [MHz]	Voltage Division Ratio EUT port to RF port [dB]	Frequency [MHz]	Voltage Division Ratio EUT port to RF port[dB]
0,01	-5.524	5	-0.043
0,025	-0.264	7,5	-0.055
0,05	-0.015	10	-0.077
0,075	-0.006	15	-0.115
0,1	-0.009	20	-0.145
0,125	-0.010	25	-0.194
0,150	-0.010	30	-0.225
0,175	-0.011	40	-0.329
0,2	-0.011	50	-0.439
0,25	-0.014	60	-0.583
0,5	-0.017	70	-0.667
0.75	-0.017	80	-0.748
1	-0.020	90	-0.939
2,5	-0.033	100	-0.925

## 50 $\mu$ H Line Impedance Stabilisation Network

Table 1 - LISN calibration data, voltage division ratio, 50 $\Omega$  // 50 $\mu$ H

### TBL50100-1B Voltage Division Factor (50 $\mu$ H + 5 Ohm) // 50 Ohm

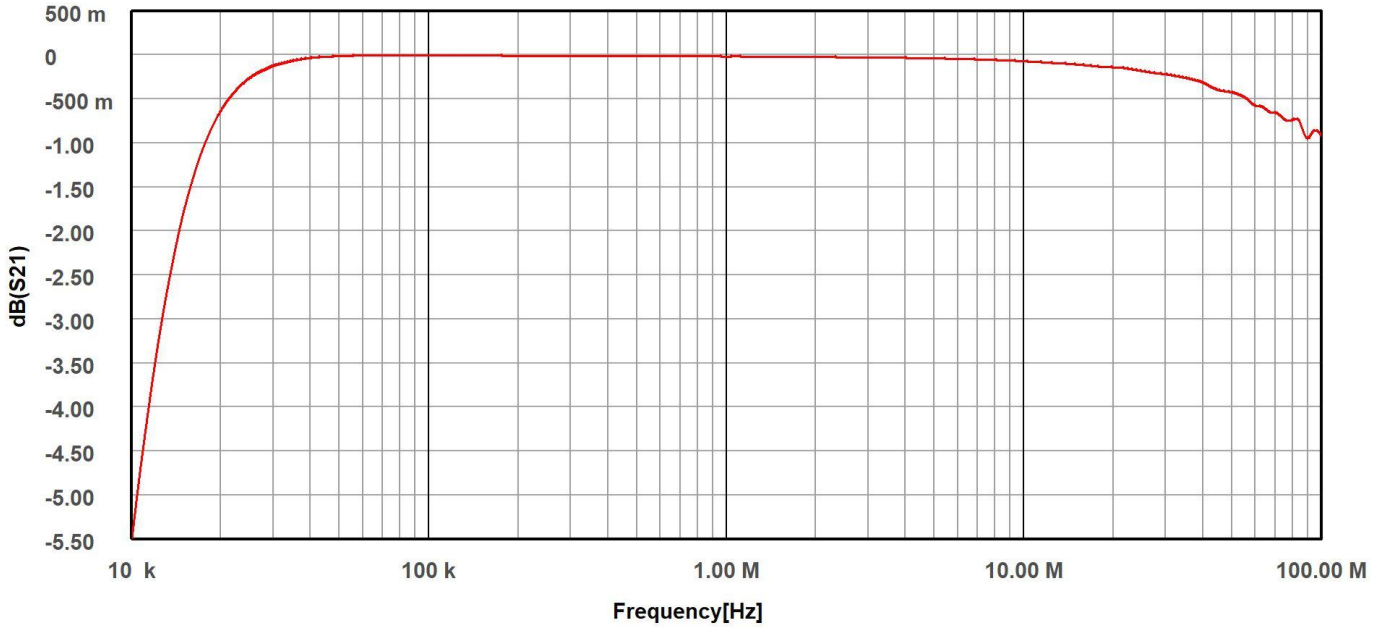

Picture 9: Voltage division ratio EUT terminals to RF connector, (50 $\mu$ H + 5 $\Omega$ ) // 50  $\Omega$ , MIL-STD

Frequency [MHz]	Voltage Division Ratio EUT port to RF port [dB]	Frequency [MHz]	Voltage Division Ratio EUT port to RF port[dB]
0,01	-5.567	5	-0.040
0,025	-0.265	7,5	-0.053
0,05	-0.013	10	-0.074
0,075	-0.005	15	-0.110
0,1	-0.007	20	-0.143
0,125	-0.009	25	-0.186
0,150	-0.010	30	-0.222
0,175	-0.010	40	-0.319
0,2	-0.010	50	-0.428
0,25	-0.012	60	-0.579
0,5	-0.015	70	-0.660
0.75	-0.015	80	-0.739
1	-0.020	90	-0.950
2,5	-0.028	100	-0.921

Table 2 - LISN calibration data, voltage division ratio, (50 $\mu$ H + 5 $\Omega$ ) // 50  $\Omega$

## 50µH Line Impedance Stabilisation Network

### 9 Application

#### **CISPR16**

By shorting the 5 Ohm resistor with the supplied high current jumper, the LISN is a  $50\mu\text{H} // 50\ \Omega$  network that can be used for CISPR 16 based conducted emission measurements in the frequency range from 150 kHz to 30 MHz. Though the LISN can be jumpered to  $(50\mu\text{H} + 5\ \Omega) // 50\ \Omega$ , it differs from a CISPR-16  $(50\mu\text{H} + 5\ \Omega) // 50\ \Omega$  LISN, because it lacks the 250µH pre-filter.

#### **MIL-STD**

Removing the jumper turns the LISN into a  $(50\mu\text{H} + 5\ \Omega) // 50\ \Omega$  LISN according to MIL-STD.

#### **Applicable MIL-STD tests:**

##### **CE101:**

Conducted emissions, audio frequency currents, power leads in the frequency range from 30 Hz – 10 kHz. Note that the LISNs only establishes a defined supply impedance for the setup. The LISNs are terminated with 50 Ω and the disturbance signal is measured with a current probe:

##### **CE102:**

Conducted emissions, radio frequency potential, power leads in the frequency range from 10 kHz to 10 MHz.

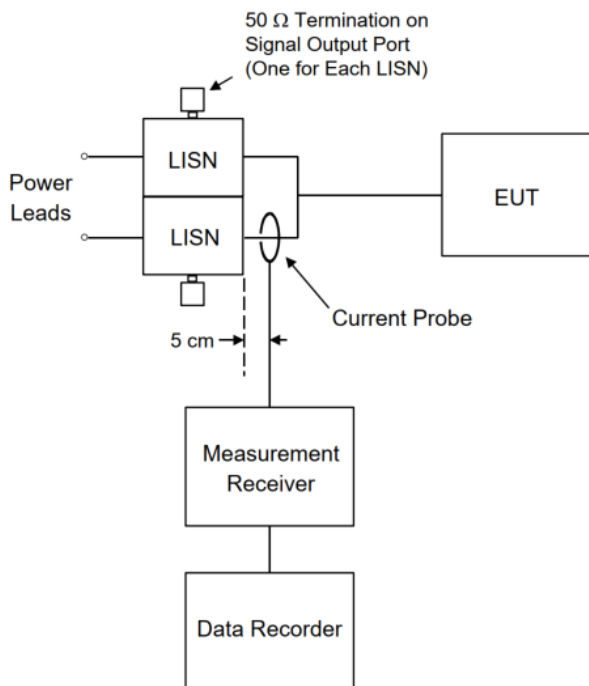

Picture 10: CE101 measurement setup

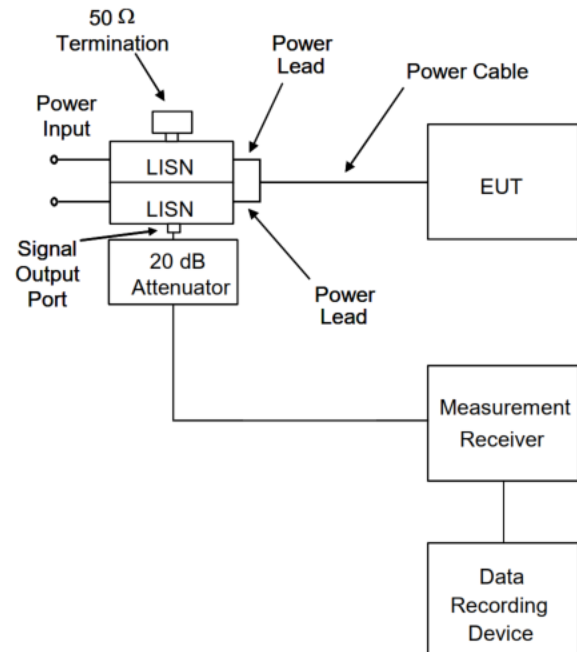

Picture 11: CE102 measurement setup

- Picture 10, 11 copied from MIL-STD-461G

## 50µH Line Impedance Stabilisation Network

Other MIL-standards, where LISNs are part of the setup:

**CS101:**

Conducted susceptibility, power leads; frequency range from 30 Hz to 150 kHz

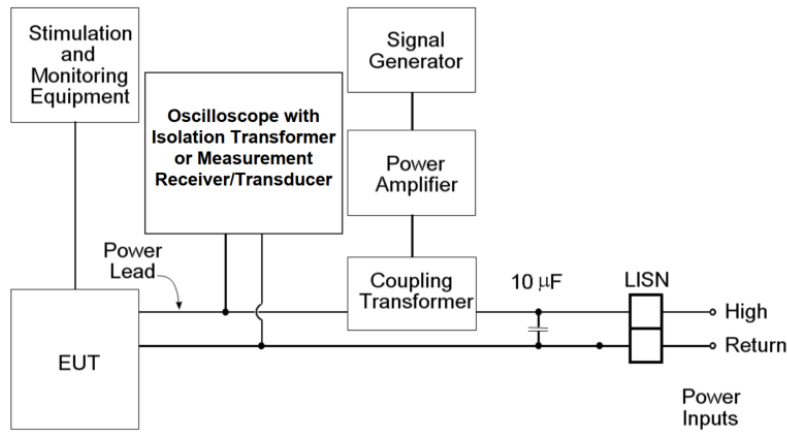

Picture 12: CS101 setup, DC or single phase AC; copied from MIL-STD-461G

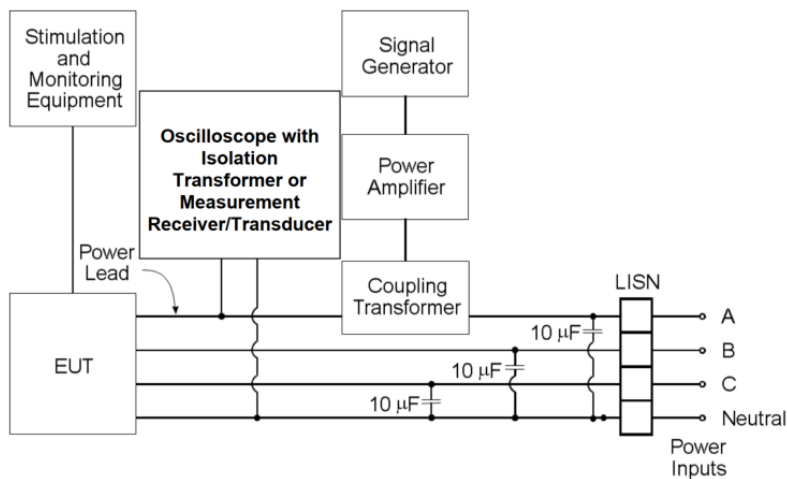

Picture 13: CS101 setup, 3- phase Y-configuration; copied from MIL-STD-461G

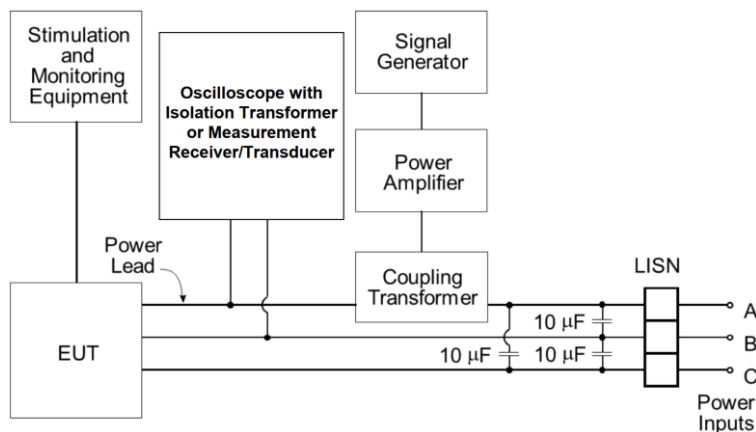

Picture 14: CS101 setup, 3- phase Delta-configuration; copied from MIL-STD-461G

## 50µH Line Impedance Stabilisation Network

**CS114 / CS115 / CS116 / CS117:**

Conducted susceptibility, bulk cable injection, RF from 10 kHz – 200 MHz / impulse excitation / damped sinusoidal transients / lightning transients setups all contain LISNs.

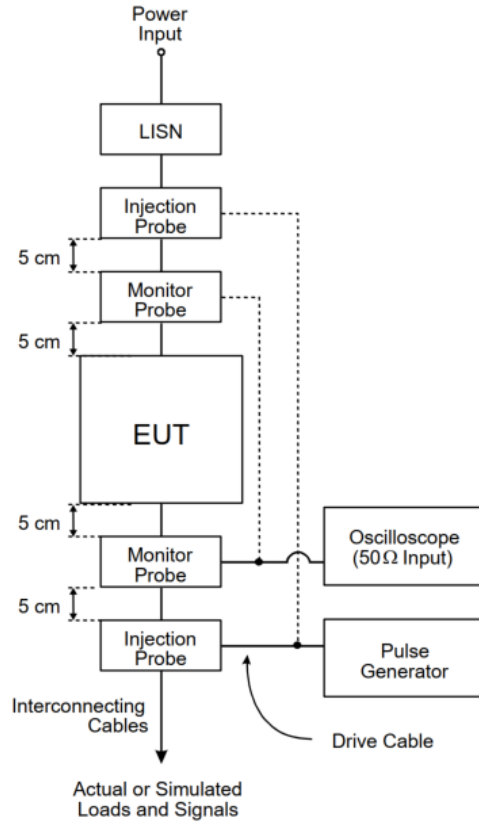

Picture 15: example CS115 bulk cable injection setup; copied from MIL-STD-461G

**RE101:**

Radiated emissions, magnetic field, frequency range from 10 Hz to 100 kHz.

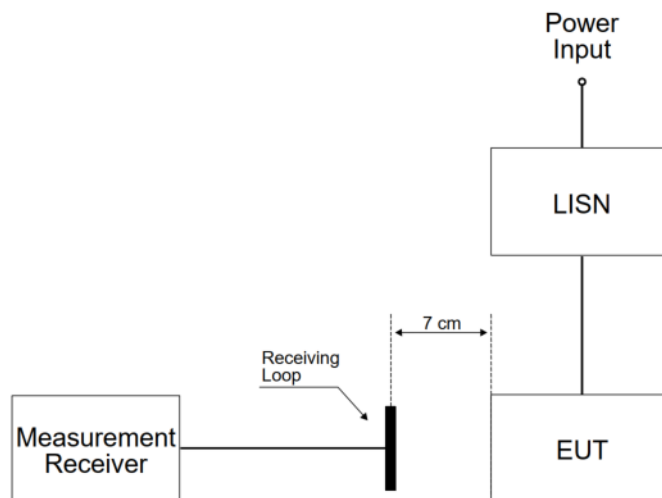

Picture 16: RE101 measurement setup; copied from MIL-STD-461G

## 50 $\mu$ H Line Impedance Stabilisation Network

### **RE102:**

Radiated emissions, electric field, up to 18 GHz

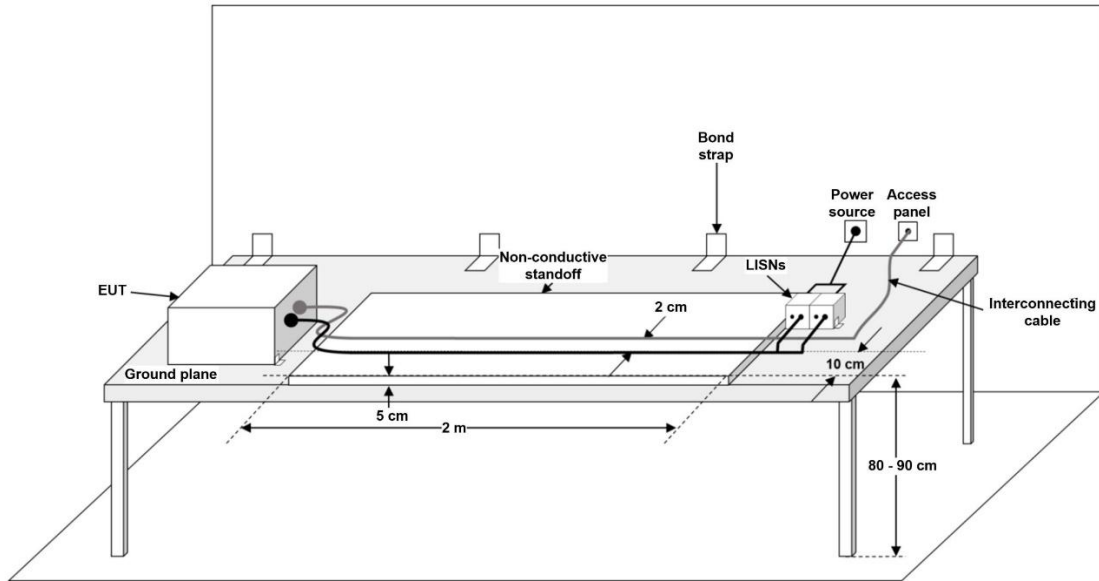

\* Images adapted from MIL-STD-461G specification

Picture 17: RE102 measurement, EUT setup; copied from MIL-STD-461G

### **RS101 / RS 103:**

Radiated susceptibility, magnetic field, 30 Hz to 100 kHz / electric field up to 40 GHz

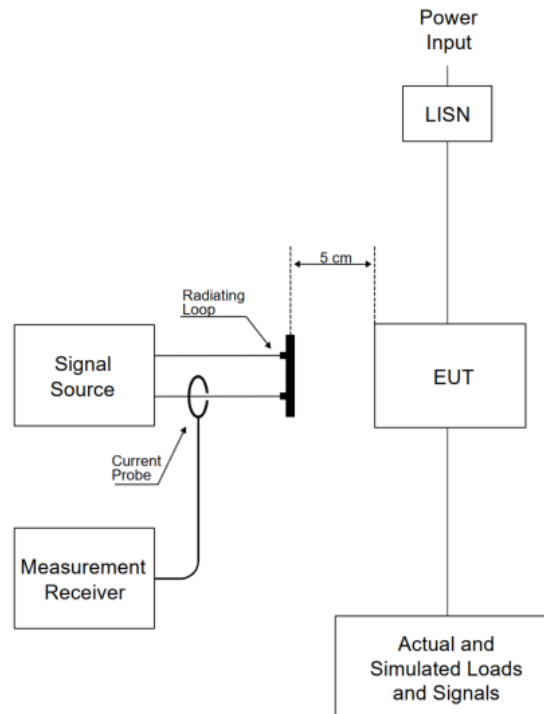

Picture 18: RS101 setup; copied from MIL-STD-461G

## 50µH Line Impedance Stabilisation Network

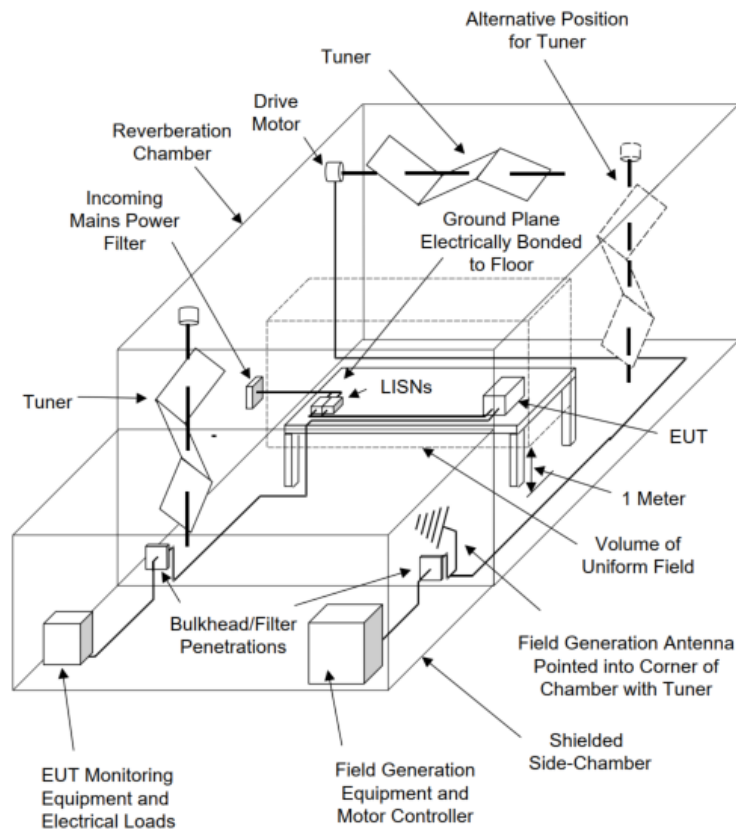

Picture 18: RS103 setup; example reverberation chamber, copied from MIL-STD-461G

### 9.1 High pass

If the spectrum analyzer or measurement receiver input impedance at 50 / 60 / 400 Hz is not 50 Ohm but high, residual AC voltage suppression at the LISN RF output is low. Moreover, high amplitude sub-harmonics at low frequencies may also cause receiver overload, nonlinear distortions or even damage. It is highly recommended to protect the analyzer / receiver input with an external filter/attenuator/transient limiter such as the TBFL1 or similar. External attenuators may also be necessary, depending on the behaviour of the EUT. The TBL50100-1B also contains a simple, 2<sup>nd</sup> order high pass filter for residual AC voltage suppression, which can be activated by setting an internal jumper, if needed.

50 Hz suppression without high pass jumpered: 23 dB @ RF output terminated with High Z

50 Hz suppression with high pass jumpered: 48 dB @ RF output terminated with High Z

According to CISPR 16 and MIL-STD, the TBL50100-1B LISN has an 8µF capacitor to ground. In AC applications, the capacitor draws a significant amount of reactive current, which would trip the mains ground fault switch. Hence, the TBL50100-1B must be supplied through an isolation transformer.

Separate measurement of differential and common mode noise can be carried out using two TBL50100-1B in combination with the Tekbox LISN Mate TBLM2.

### 9.2 Jumpers

By default, the LISN is jumpered to 50µH + 50Ω // 50 Ω and high pass filter OFF. To change the settings, remove the cover of the housing to access the jumpers. The PCB contains two “parking positions”, where the jumpers can be stored, when not needed. Jumper part nr.: Harwin D3087-98

## 50µH Line Impedance Stabilisation Network

### 9.3 General Wiring Variants

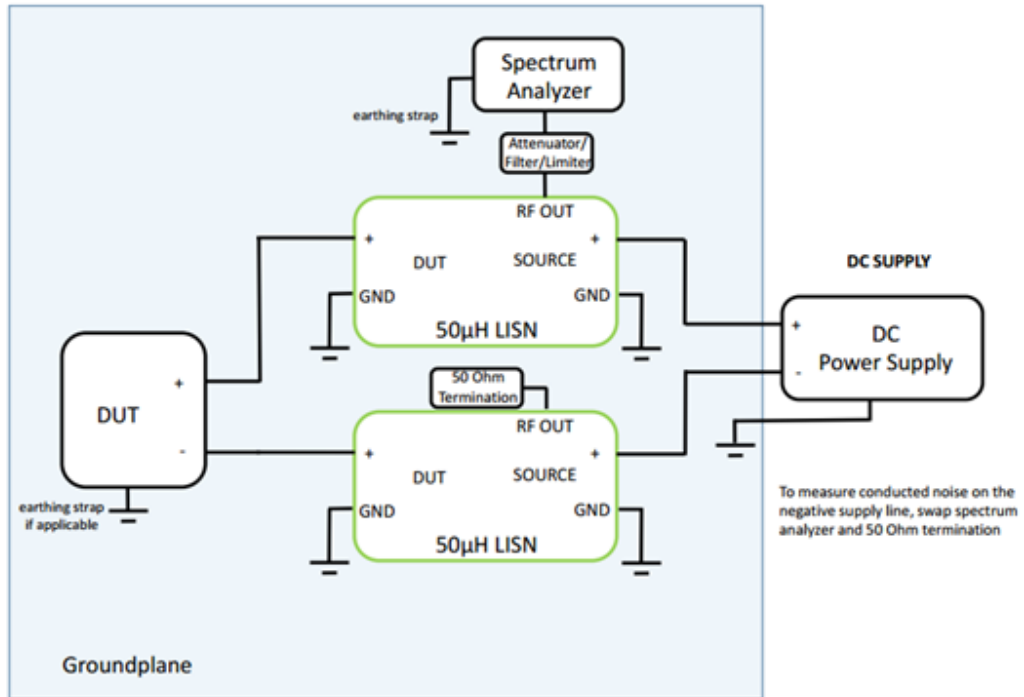

Picture 13: Measurement set up for DC supplied equipment

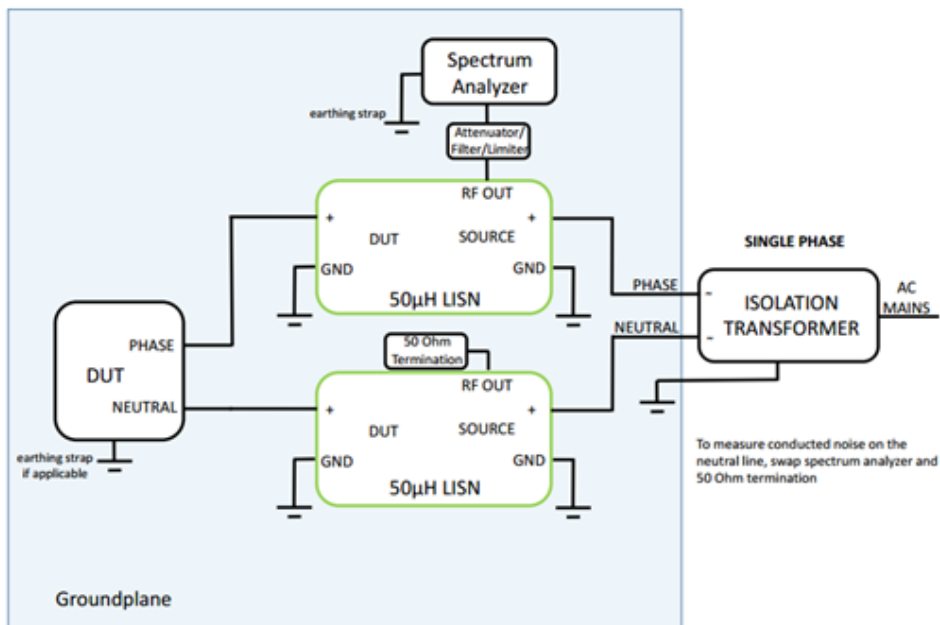

Picture 14: Measurement set up for single phase AC supplied equipment

## 50µH Line Impedance Stabilisation Network

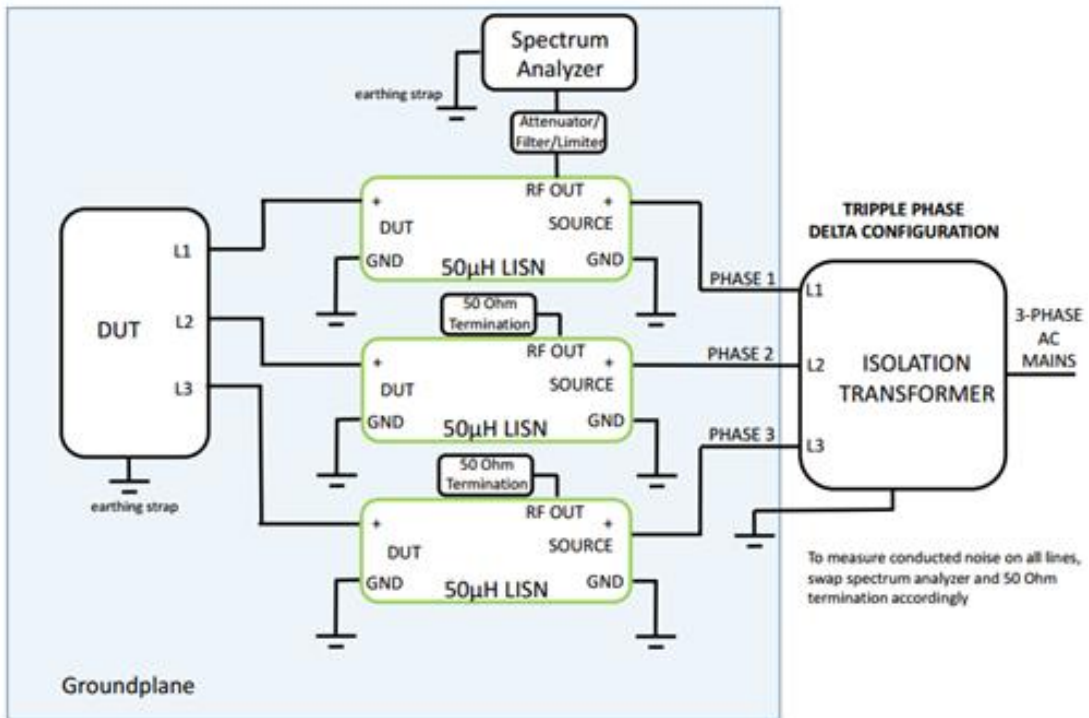

Picture 15: Measurement set up for triple phase AC supplied equipment in Delta configuration

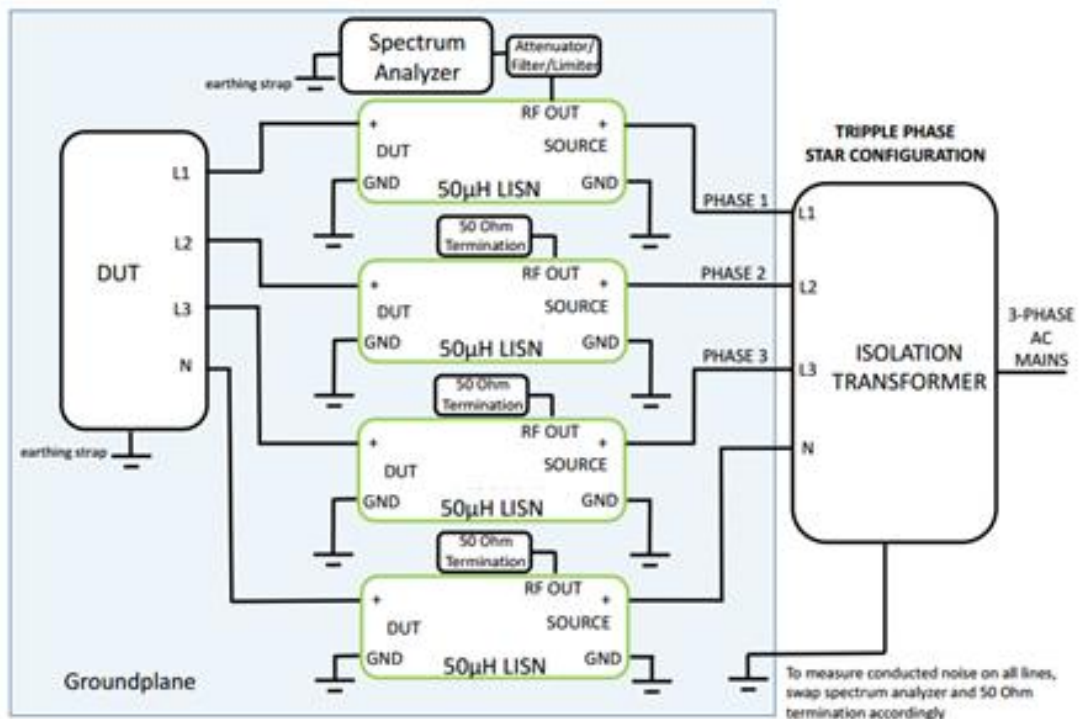

Picture 16: Measurement set up for triple phase AC supplied equipment in Star configuration

## 50µH Line Impedance Stabilisation Network

### 10 Ordering Information

Part Number	Description
TBL50100-1B	50µH LISN, 1 pc. 75 cm N-male to N-male RG223 cable NIST traceable calibration data / certificate

#### Accessories

Part Number	Description
TBL05100-1C-CAL	Calibration kit; calibration adapter BNC-female; OSL calibration box



Picture 17: Calibration kit

### 11 History

Version	Date	Author	Changes
V1.0	29.06.2026	Mayerhofer	Creation of the document

Table 5 – History