

## SDI-12 to Analogue Interface Board

The TBS02A-IFB is an 8 channel SDI-12 to analogue interface board for A/D conversion of sensor signals, primarily designed as evaluation board for the TBS02A module. A/D conversion and configuration of the board is controlled via SDI-12 commands. The interface board is equipped with signal conditioning circuits for various input voltage ranges. It offers low current consumption and is built to fit into an off the shelf IP67 housing.

Each channel can be independently scaled with a 3<sup>rd</sup> order polynomial to enable gain and offset calibration of the connected sensors.

A built in thermal sensor offers additional versatility.

The TBS02A IFB provides digital signals for the power management of the connected sensors. Two on board, high side FET- switches can be routed to any control signal and used to power on/off connected sensors.

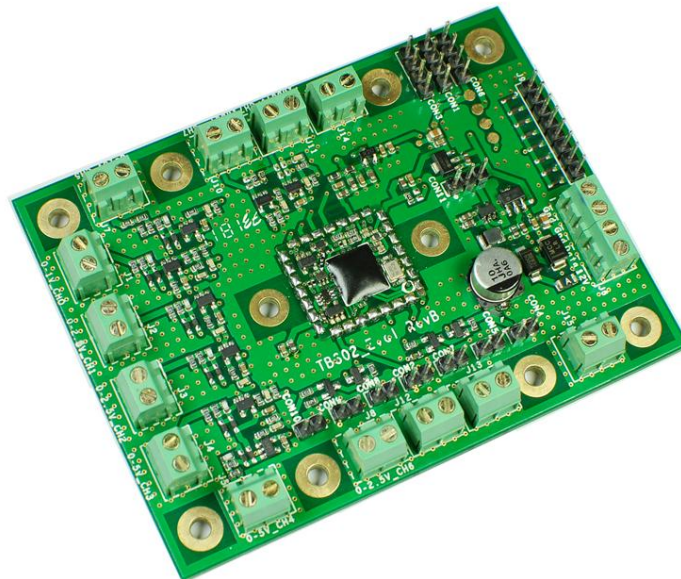

TBS02A-IFB 8 Channel Analogue to SDI-12 Interface Board

### Features

- SDI-12 / ANALOGUE Interface
- 8 x 12 Bit ADC channels
- 7 single ended and 1 differential input
- 1 x 0...1V, 2x 0...2.5V, 2 x 0...5V, 1 x 0...10V, 1 x 0...2.5V unconditioned, 1 x differential / current loop inputs
- Input over-voltage protection
- Integrated 12 Bit temperature sensor
- Configurable sensor power management signal for each channel
- Configurable slope and offset for each channel
- Power down mode
- SDI-12 V1.3
- 6-16V supply voltage
- 94mm x 71mm x 13mm
- Compatible with Fibox PC081206 housing
- Operating temperature range:  
-40°C ... +85°C

### Target Applications

- SDI-12 sensor networks

# SDI-12 to Analogue Interface Board manual

## Contents

<b>1</b>	<b>INTRODUCTION</b>	<b>3</b>
1.1	MEASUREMENT	3
1.2	PRODUCT FEATURES	3
1.3	CALIBRATION	3
1.4	INSTALLATION	4
1.5	SDI-12	4
<b>2</b>	<b>APPLICATION EXAMPLES</b>	<b>5</b>
<b>3</b>	<b>HARDWARE DESCRIPTION</b>	<b>6</b>
<b>4</b>	<b>FUNCTIONAL DESCRIPTION</b>	<b>7</b>
4.1	CONNECTOR OVERVIEW	7
4.1.1	Analog input terminal blocks	7
4.1.2	Internal voltages header CON1	7
4.1.3	Power management jumper CON11	7
4.1.4	Power management header J9	8
4.1.5	High side switch headers CON4, 5, 7, 8, 9, 10	8
4.1.6	Spare terminal blocks J12, J13, J14, J15; Header CON3	9
4.1.7	SDI-12 terminal blocks J6	9
4.2	OFFSET/GAIN ERROR	9
<b>5</b>	<b>ORDERING INFORMATION</b>	<b>10</b>
<b>6</b>	<b>HISTORY</b>	<b>10</b>

## Tables

Table 1 – Ordering Information	10
Table 2 – History	10

## Figures

Figure 1 – Analogue sensors connected to TBS02A-IFB and to TBS03 SDI-12 to USB converter	5
Figure 2 – Analogue sensors connected to TBS02A-IFB and to Remote Telemetry Unit or Data Recorder	5
Figure 3 – Connector positions	6

# SDI-12 to Analogue Interface Board manual

## 1 Introduction

The TBS02A-IFB is primarily designed as an evaluation board for the TBS02A module. In order to extend its scope of application, the TBS02A-IFB can be mounted into an off the shelf housing. Using an off the shelf housing with IPC67 rating such as the Fibox PC081206, the TBS02A-IFB can be used as SDI-12 to analogue interface for outdoor sensor networks.

### 1.1 Measurement

The TBS02A-IFB offers 8 input channels:

Channel 0	0V ... 1V	protected, Rin=1M $\Omega$ , divide by 2,5 (=scale with 0,4) to get true voltage
Channel 1	0V ... 2.5V	protected, Rin=1M $\Omega$ , measurement value = true voltage
Channel 2	0V ... 2.5V	protected, Rin=1M $\Omega$ , measurement value = true voltage
Channel 3	0V ... 5V	protected, Rin=1M $\Omega$ , multiply with 2 (=scale with 2) to get true voltage
Channel 4	0V ... 5V	protected, Rin=1M $\Omega$ , multiply with 2 (=scale with 2) to get true voltage
Channel 5	0V ... 10V	protected, Rin=13K $\Omega$ , multiply with 4 (=scale with 4) to get true voltage
Channel 6	0V ... 2.5V	unprotected, Rin=1M $\Omega$ , measurement value = true voltage
Channel 7	0mA ... 20 mA	unprotected, Rin=51 $\Omega$ , 0....20mA = 0...2,027V

Reference voltage: 2.5V,  $\pm 0,08\%$ , 50ppm/ $^{\circ}\text{C}$

ADC Resolution: 12 bit.

### 1.2 Product Features

- Measurement of input channels with individual M-Commands
- Independent setting of the response time of each channel, configurable with Extended SDI-12 commands
- Independent sensor power management control outputs for each channel, configurable with Extended SDI-12 commands
- The measurement result of each channel can be independently scaled with a third order polynomial using Extended SDI-12 commands
- Dimensions: 94mm x 71mm x 13mm
- Can be fitted into IP67 housing of FIBOX, model PC081206
- Operating temperature range: -40 ... +85 $^{\circ}\text{C}$

### 1.3 Calibration

Any offset or gain error of the analogue system (sensor + TBS02A-IFB analogue frontend) can be compensated using the scaling capability of the TBS02A-IFB.

## SDI-12 to Analogue Interface Board manual

### 1.4 Installation

The TBS02A-IFB is compatible with any data logger or remote telemetry unit with SDI-12 interface. Refer to the data logger or RTU manual and to chapter 2 of this datasheet.

### 1.5 SDI-12

SDI-12 is a standard for interfacing data recorders with microprocessor-based sensors. SDI-12 stands for serial/digital interface at 1200 baud. It can connect multiple sensors with a single data recorder on one cable. It supports up to 60 meter cable between a sensor and a data logger.

The SDI-12 standard is prepared by

**SDI-12 Support Group  
(Technical Committee)  
165 East 500 South  
River Heights, Utah  
435-752-4200  
435-752-1691 (FAX)  
<http://www.sdi-12.org>**

The latest standard is version V1.3 which dates from July 18<sup>th</sup>, 2005. The standard is available on the website of the SDI-12 Support Group.

More information on SDI-12 is presented in chapter 3.

# SDI-12 to Analogue Interface Board manual

## 2 Application Examples

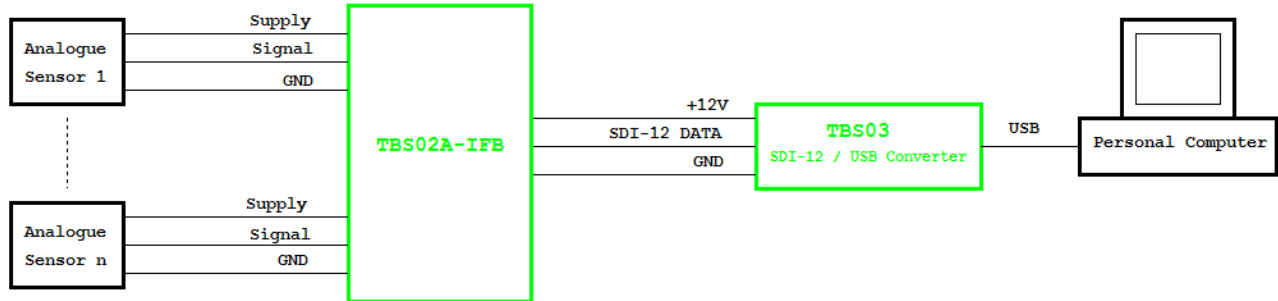

Figure 1 – Analogue sensors connected to TBS02A-IFB and to TBS03 SDI-12 to USB converter; setup for controlling / testing sensors and for PC based data recording

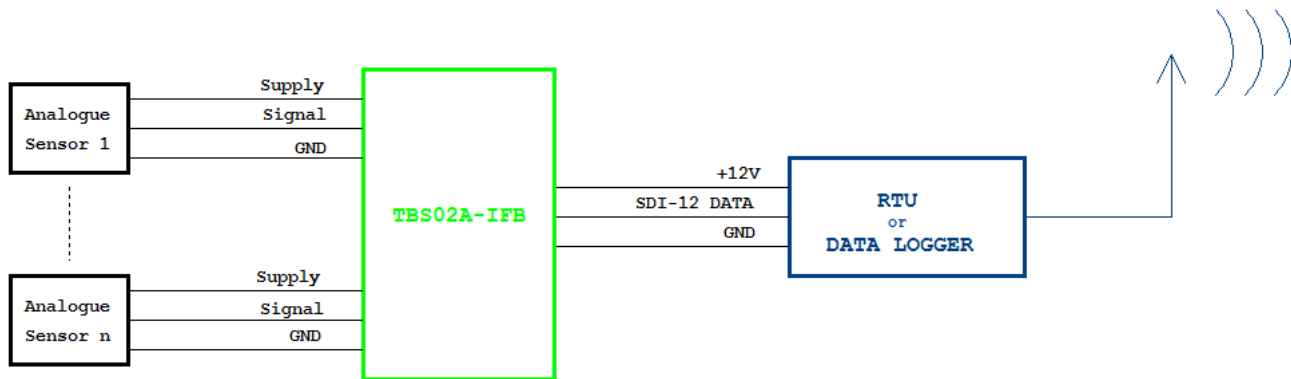

Figure 2 – Analogue sensors connected to TBS02A-IFB and to Remote Telemetry Unit or Data Recorder

# SDI-12 to Analogue Interface Board manual

## 3 Hardware Description

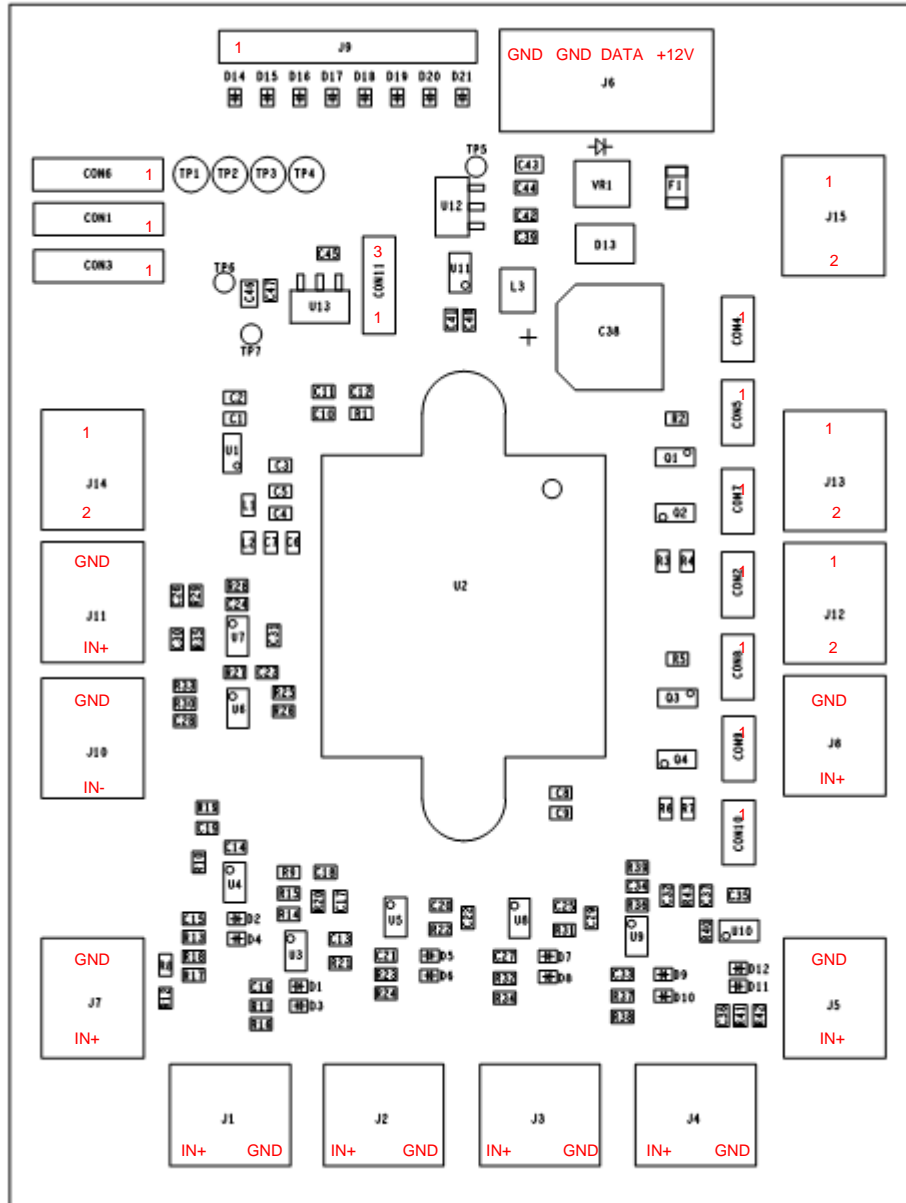

Figure 3 – Connector positions

# SDI-12 to Analogue Interface Board manual

## 4 Functional Description

### 4.1 Connector Overview

#### 4.1.1 Analog input terminal blocks

The TBS02A-IFB provides 9 screw terminal blocks to connect to the 8 analog channels. There is one terminal block each for channel 0 to 6 and two terminal blocks for the symmetric analog input channel 7.

The assignment is as below:

Channel #	input range	input protection	terminal block #
Channel 0	0V ... 1V	over voltage protection	J1
Channel 1	0V ... 2.5V	over voltage protection	J2
Channel 2	0V ... 2.5V	over voltage protection	J3
Channel 3	0V ... 5V	over voltage protection	J4
Channel 4	0V ... 5V	over voltage protection	J5
Channel 5	0V ... 10V	over voltage protection	J7
Channel 6	0V ... 2.5V, unprotected	unprotected	J9
Channel 7	0mA ... 20 mA	unprotected, Ri= 51 Ohm	J10, J11

#### 4.1.2 Internal voltages header CON1

Header CON1 provides access to the internal LDO voltages and to the reference voltage

CON1 Pin #	voltage	comment
Pin 1	5V	digital supply voltage LDO output
Pin 2	3.3V	digital supply voltage LDO output
Pin 3	5V	analogue supply voltage LDO output; enabling of this LDO depends on the jumper position of header CON11; refer to chapter 4.1.3
Pin 4	2.5V	voltage reference output; the reference IC is powered by the 5V analog LDO

#### 4.1.3 Power management jumper CON11

The jumper setting of CON11 determines the operation mode of the LDO for the 5V analogue supply rail and the 2.5V ADC reference voltage.

Jumper Position	comment
Pin 1/2	enabling of the 5V analogue supply rail is controlled by the power management signals CTRL0...CTRL7 – the LDO is only enabled during measurement
Pin 2/3	the 5V analogue supply rail and the reference voltage is always powered

# SDI-12 to Analogue Interface Board manual

## 4.1.4 Power management header J9

The power management header gives access to the sensor power management signals. The sensor power management signals can be used to control high side switches in the sensor supply lines

J9 Pin#	reference	comment
Pin 1	CTRL0	power management signal for channel 0
Pin 2	CTRL1	power management signal for channel 1
Pin 3	CTRL2	power management signal for channel 2
Pin 4	CTRL3	power management signal for channel 3
Pin 5	CTRL4	power management signal for channel 4
Pin 6	CTRL5	power management signal for channel 5
Pin 7	CTRL6	power management signal for channel 6
Pin 8	CTRL7	power management signal for channel 7

## 4.1.5 High side switch headers CON4, 5, 7, 8, 9, 10

The TBS02A-IFB provides two high side FET switches. Max. rating: 20V/2.4A

The high side switch control inputs can be connected to a power management signal and the supply inputs can be hooked up to any supply voltage within the limits of the maximum ratings of the switch. The supply output of the high side switches can then be used as sensor supply.

### High side switch #1:

CON4 Pin#	comment
Pin1	Ground
Pin2	Supply Input

CON5	comment
Pin1	Ground
Pin2	Supply Output

CON7	comment
Pin1	Ground
Pin2	Control Input

### High side switch #2:

CON8	comment
Pin1	Ground
Pin2	Supply Input

CON9	comment
Pin1	Ground
Pin2	Supply Output

CON10	comment
Pin1	Ground
Pin2	Control Input



## SDI-12 to Analogue Interface Board manual

### 4.1.6 Spare terminal blocks J12, J13, J14, J15; Header CON3

This screw terminal blocks are connected to Pins of header CON3 and can be connectd to the high side switches or used for other purposes.

<b>J12</b>	<b>comment</b>
Pin1	Ground
Pin2	connected to CON3 Pin1

<b>J13</b>	<b>comment</b>
Pin1	Ground
Pin2	connected to CON3 Pin2

<b>J14</b>	<b>comment</b>
Pin1	Ground
Pin2	connected to CON3 Pin3

<b>J15</b>	<b>comment</b>
Pin1	Ground
Pin2	connected to CON3 Pin4

### 4.1.7 SDI-12 terminal blocks J6

<b>J6 Pin#</b>	<b>comment</b>
Pin1	Ground
Pin2	Control Input

## 4.2 Offset/Gain error

The analog front end is affected with a offset error of typ. 1mV

In applications, where the offset error can not be tolerated, it can be compensated using an extended SDI-12 command. Refer to chapter 6.11 of the TBS02A manual.

Before calibrating the offset of any channel, connect a short wire across the corresponding input terminal block of this channel. Then measure the input voltage (=offset voltage) using the appropriate measurement commands and use the measurement result to shift the output accordingly.

The gain error of the analog front end typically is < 3mV when measured with 1.5V input voltage.

If required, the gain error can be compensated using the scaling capability of the TBS02A. Connect the input terminal of the desired channel to an accurate voltage source, measure the voltage and scale the output accordingly. An easy method is to hook up a 1,5V battery to the input and then measure the battery voltage across the terminal block with a Fluke or any other quality multimeter. Then measure the voltage with the TBS02A-IFB. From the difference of the two results you can calculate the necessary scaling value to compensate for the gain error. For scaling refer to chapter 6.11 of the TBS02A manual.

# SDI-12 to Analogue Interface Board manual

## 5 Ordering Information

Part Number	Description
TBS02A-IFB	TBS02A evaluation board, 8 channel analogue to SDI-12 interface

Table 1 – Ordering Information

## 6 History

Version	Date	Author	Changes
V1.0	10.02.2011	Mayerhofer	Creation of the document

Table 2 – History