



TBVNA-6000

6 GHz Vector Network Analyzer

Programming Manual

Rev.1.0

Certification

TekBox certifies that this product met the published specifications at the time of shipment from the factory.

Warranty

This product is warranted against defects in material and workmanship for a period of 2 years from the date of delivery. During this warranty period, TekBox will, at its own option, either repair or replace products which prove to be defective. For warranty service or repair, this product must be returned to the TekBox electronics factory or to the distributor, where the product was purchased.

The foregoing warranty shall not apply to defects resulting from improper or inadequate maintenance by the Buyer, unauthorized modification or misuse, operation outside the environmental specifications for the product, or improper site preparation or maintenance. Tekbox bears no responsibility for any results of tests run by operating the test equipment or for the impact on the sample device.

No other warranty is expressed or implied. TekBox specifically disclaims the implied warranties of merchantability and fitness for a particular purpose. The remedies provided herein are the Buyer's sole and exclusive remedies. TekBox shall not be liable for any direct, indirect, special, incidental, or consequential damages, whether based on contract, tort, or any legal theory.

The contents of this manual are subject to change without notice.

Although every effort has been made to ensure that the content of this manual is accurate and complete, please contact us if you find any unclear points, errors, omissions, or other inconsistencies.

1 Table of Contents

2	Introduction.....	5
2.1	Setting IP parameters in the analyzer software	6
2.2	Setting the Analyzer to remote control mode	7
2.3	SCPI language support.....	8
2.4	Setting up NI MAX to communicate with the Analyzer.....	9
3	SCPI Command Reference	12
3.1	Basic Queries	12
3.1.1	*IDN?	12
3.1.2	CONNECTED?.....	12
3.1.3	STATUS?.....	12
3.2	Basic Commands.....	12
3.2.1	MODE <mode>	12
3.2.2	MODE?.....	12
3.2.3	*RCL <filename>	13
3.2.4	LIMITS	13
3.3	Calibration subsystem	13
3.3.1	CAL:LOAD <filename>.....	13
3.3.2	CAL:VALID?	13
3.3.3	CAL:CLEAR.....	13
3.3.4	CAL:DC_COMPENSATION	13
3.3.5	CAL:EXTENSION:PORT1 <delay>,<loss>,<Z0>.....	14
3.3.6	CAL:EXTENSION:PORT2 <delay>,<loss>,<Z0>.....	14
3.3.7	CAL:EXTENSION:PORT1?.....	14
3.3.8	CAL:EXTENSION:PORT2?.....	14
3.4	Parameter System	14
3.4.1	PARAM:FREQ:START <freq in Hz> and PARAM:FREQ:START?	14
3.4.2	PARAM:FREQ:STOP <freq in Hz> and PARAM:FREQ:STOP?	15
3.4.3	PARAM:PWR and PARAM:PWR?	15
3.4.4	PARAM:POINTS and PARAM:POINTS?	15
3.4.5	PARAM:SWEEP and PARAM:SWEEP?	15
3.4.6	PARAM:BW <freq in Hz> and PARAM:BW?.....	15
3.4.7	PARAM:PORT1:ATT <value> and PARAM:PORT1:ATT?.....	16
3.4.8	PARAM:PORT2:ATT <value> and PARAM:PORT2:ATT?.....	16

3.4.9	PARAM:AVERAGE <value> and PARAM:AVERAGE?	16
3.5	The Memory subsystem	17
3.5.1	MEMORY:LOAD <nr>,<filename>.....	17
3.5.2	MEMORY:COPY <nr>	17
3.5.3	MEMORY:CLEAR <nr>.....	17
3.5.4	MEMORY:VALID? <nr>	17
3.6	Read Data Commands	18
3.6.1	READ:TRACE:SINGLE <diag_name>,<trace_name>,<x-value>	18
3.6.2	READ:TRACE <diag_name>,<trace_name>	19
3.6.3	READ:MARKER <diag_name>,<trace_name>.....	19
3.6.4	READ:SPAR:S11, READ:SPAR:S12, READ:SPAR:S21, READ:SPAR:S22	20
3.6.5	READ:BODE:CHA, READ: BODE:CHB, READ: BODE:CH1, READ: BODE:CH2.....	20
3.7	Marker Functions	21
3.7.1	MARKER:ADD <diag_name>,<trace_name>,<marker_name>.....	21
3.7.2	MARKER:FUNC <diag_name>,<trace_name>,<marker_name>,<marker_function>,<marker parameter>	21

2 Introduction

Since the TBVNA-6000 does not include a hardware-based GPIB interface, remote control by third-party software is implemented entirely in software. The analyzer communicates with the controlling PC via the USB interface using a proprietary protocol. However, the PC-based analyzer software provides a TCP/IP Ethernet interface that supports selected parts of the SCPI standard. Please refer to the SCPI documentation for detailed information.

Third-party software can establish a TCP/IP connection to the analyzer software in order to exchange commands and data. Communication is purely ASCII-based, and each command must be terminated with a newline character (`\n`, hexadecimal value `0x0A`).

The third-party application may run either on the same computer as the TBVNA System Software or on a separate computer connected via Ethernet to the PC controlling the TBVNA.

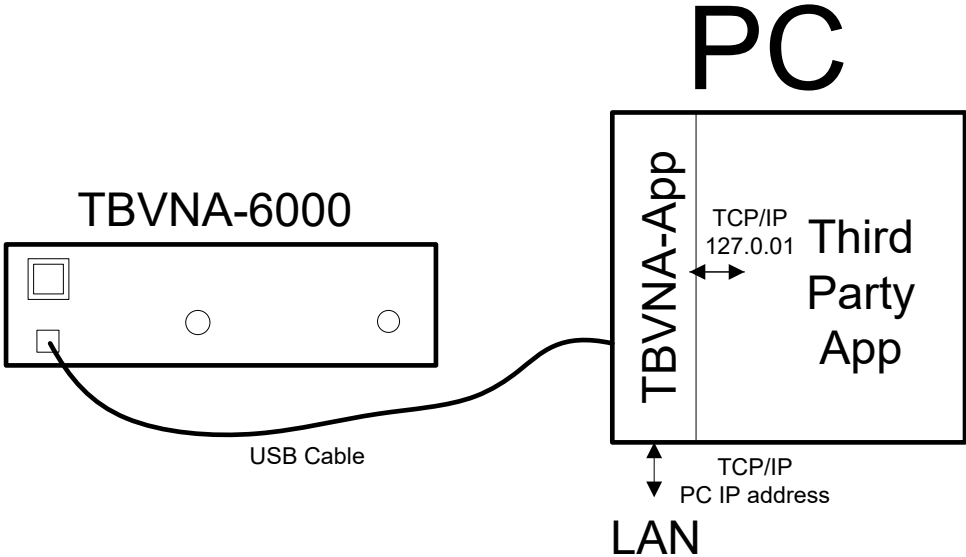

Fig.2.1.1 Basic Remote Control Connection

2.1 Setting IP parameters in the analyzer software

To change the IP-address or port number select the item "System Service" in the "System" menu of the drop-down menu of the Analyzer system software. Please note that you must first select "Unlock Calibration" from the "System" menu. Following dialog will appear:

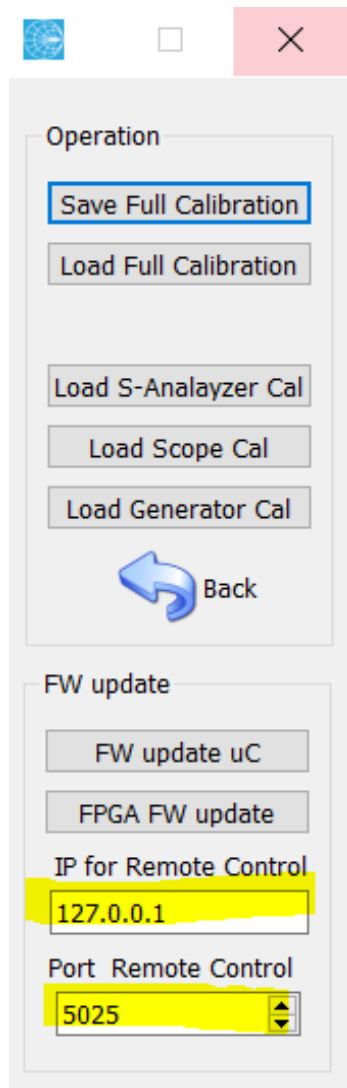

Fig.2.1.2 System Service Dialog.

Enter the Server listening IP address and Port number in the above dialog window. Click "Back" to save the settings. The settings shown above are the default values. Please note, that the port number 5025 is assigned to SCPI by the IANA (Internet Assigned Numbers Authority).

2.2 Setting the Analyzer to remote control mode

First, configure Remote Control in the analyzer software to enable TCP/IP connection.

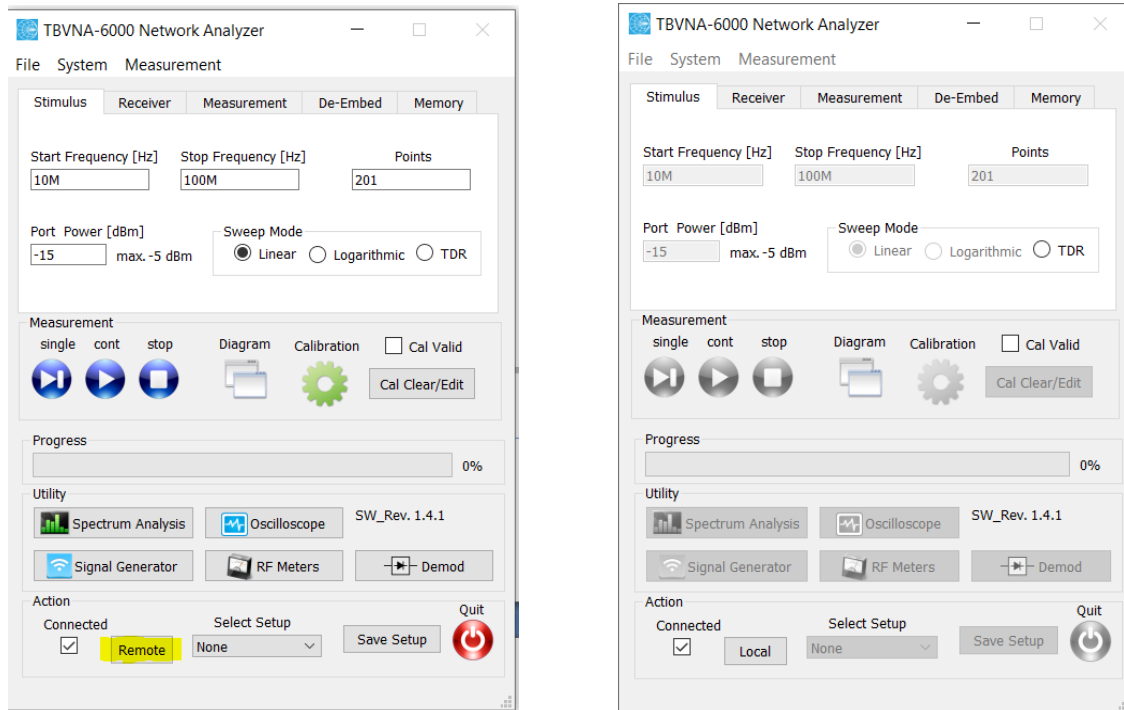

Fig.2.1.3 Turning on Remote Control.

To enable remote control, click the yellow-highlighted “Remote” button. Once activated, all local controls will be disabled and greyed out automatically, and control of the analyzer will be transferred entirely to the TCP/IP interface. Please note, that the text of the Remote button will change to “Local” in remote-control mode.

To disable remote control, press the “Local” button. This will terminate the TCP/IP connection and re-enable all manual controls.

2.3 SCPI language support

As mentioned before, not every SCPI language element is supported. Please see the table below for what is supported and what is not:

Feature	Example	Supported	Comment
Command concatenation by semicolon (;)	MEM:COPY;MEM:CLEAR	YES	Fully supported.
Command Short Cut	MEAS instead of MEASure	NO	
Command Path Memory	READ:SPAR:S21 and then just send :S12	NO	Full Command has to be sent each time.

Table 2.3 Supported SCPI Features.

The Software does not allow command processing if another command is in progress. If a longer measurement is in progress, no additional commands or queries may be executed. However, submitted instructions and queries are not lost; instead, they are saved in a command queue and processed sequentially.

2.4 Setting up NI MAX to communicate with the Analyzer.

Set your TBVNA into “remote-mode” and start the NI MAX application.

To access the device tree, scroll to "Devices and Interfaces" on the left side of the program window and left-click. Navigate to "Network Devices" and right-click to access the context menu. Choose "Create new VISA TCP/IP Resource..." .

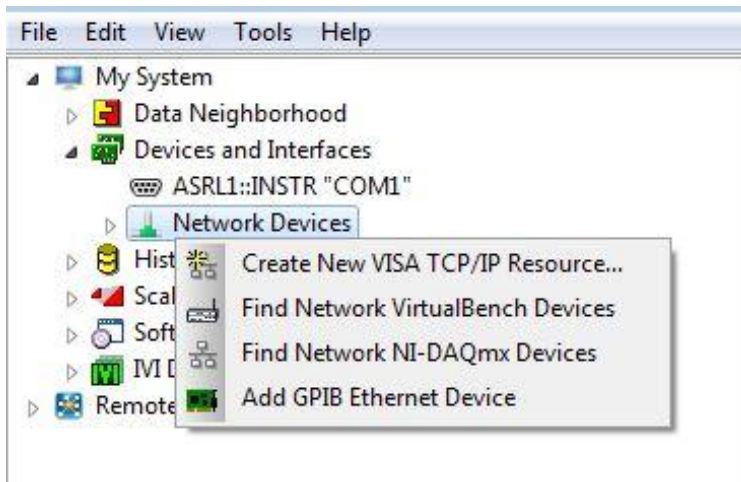

Fig.2.4.1 NI MAX main Window.

A new window appears; select “Manual Entry of Raw Socket” and click Continue.

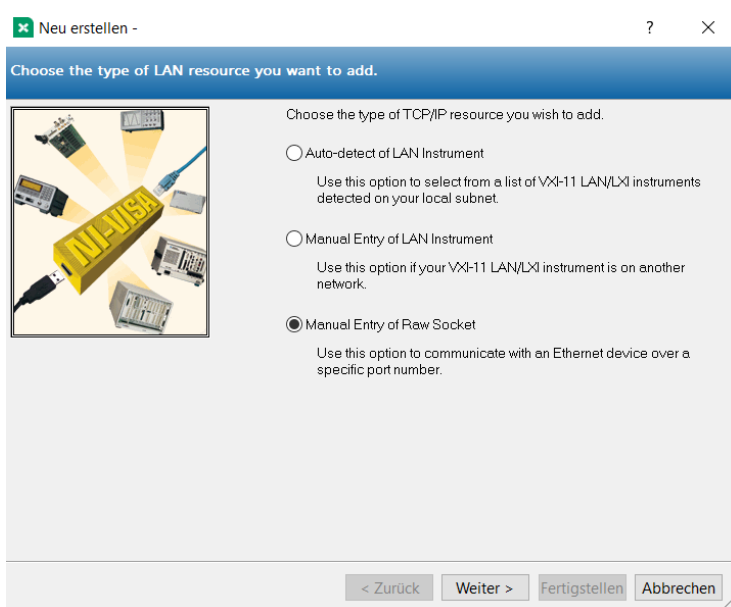

Fig.2.4.2 Create new device.

Enter the IP address and port number that you used to set up the TBVNA software in the following window.

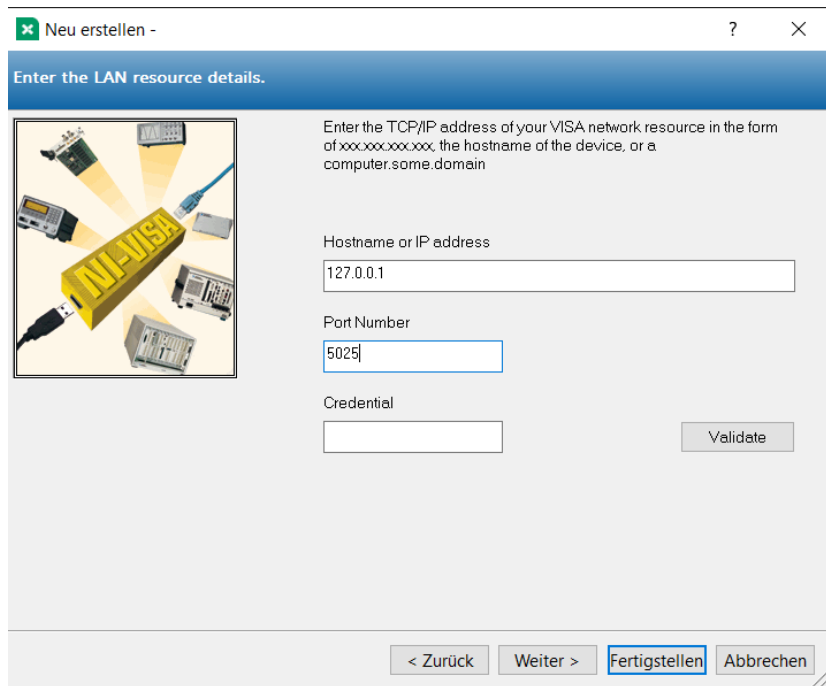

Fig.2.4.3 Enter the Ethernet LAN data.

Now press “Finish” and check the main window:

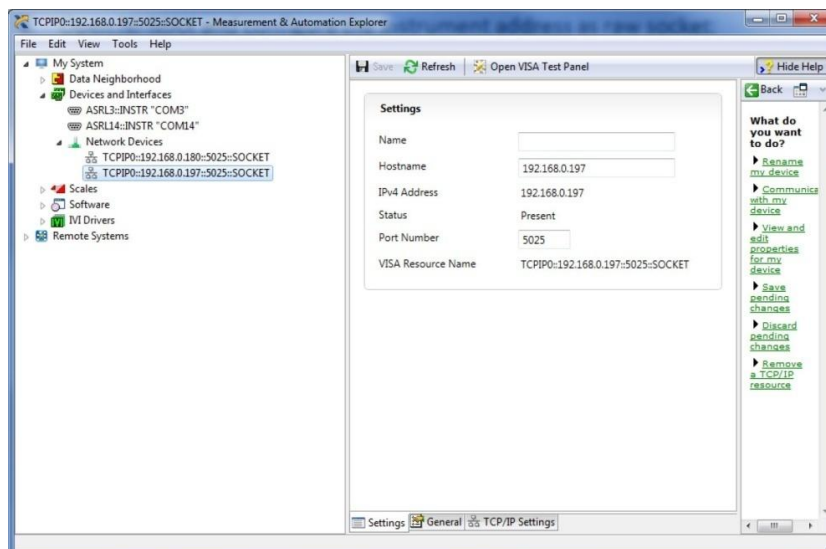

Fig.2.4.4 Main Window with added TCPIP devices.

On the right side, you may give the interface a name, such as TBVNA.

Check whether the Status is "Present". If not, please ensure that all data were input correctly and that no firewall is preventing connection.

From now on, the TBVNA is available in NI applications as a TCPIP device.

You can open the VISA Test panel, however, before you can send data, the I/O Settings must be configured:

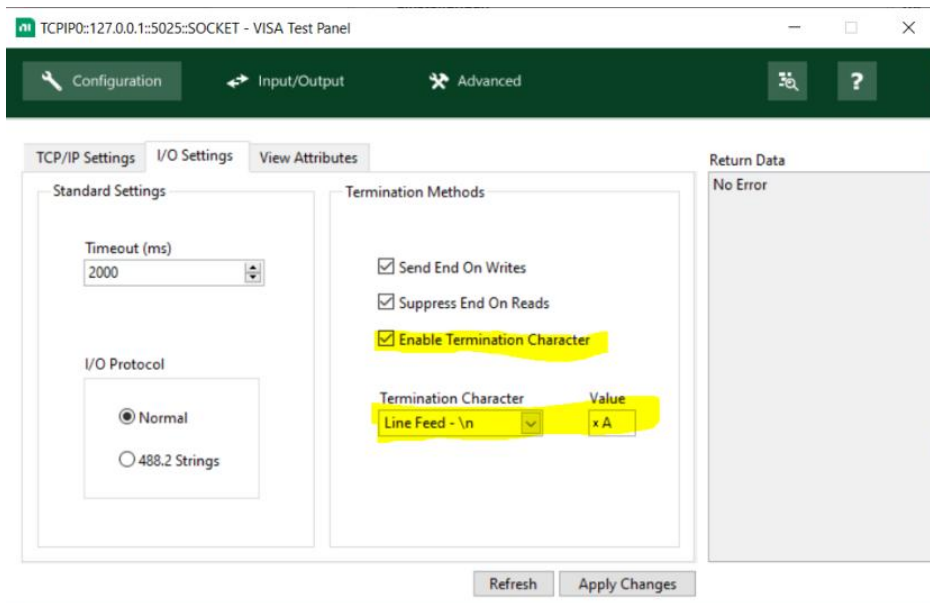

Fig.2.4.5 I/O Settings in Test Panel

Please enable the "Termination Character" as the TCPIP interface does not support an EOI with a hardware line. Before you proceed, press "Apply Changes".

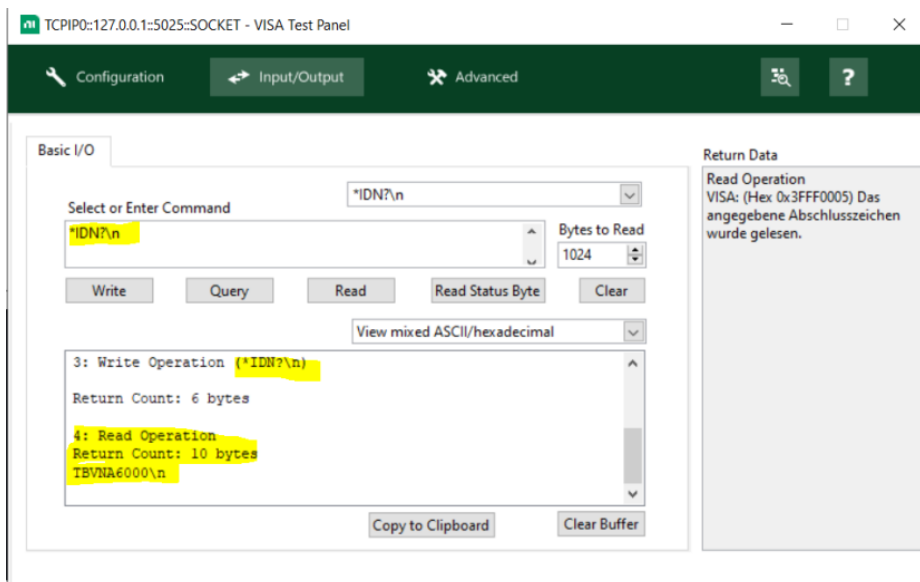

Fig.2.4.6 TBVNA *IDN? Query.

Try using the IDN command to query as shown above. "TBVNA6000" will be the response. Now the TBVNA is now ready to be used in any NI applications.

3 SCPI Command Reference

3.1 Basic Queries

According to the SCPI standard, the TBVNA does not discriminate between upper-case and lower-case letters. This also holds true for filenames. Names and filenames must be set under single quotes ‘ ’, like ‘filename’.

3.1.1 *IDN?

The *IDN? Query can be used to check if the analyzer software is present and running. The TBVNA will answer with “TBVNA6000”. This does not verify if the TBVNA is switched on and connected.

3.1.2 CONNECTED?

The CONNECTED? query checks if the analyzer is present via the USB interface and ready to receive data. The possible replies are “YES” or “NO”.

3.1.3 STATUS?

The STATUS? query checks if a previous operation was successful. Not all operations affect the status variable, and the meaning of the result may vary depending on the prior command. Possible responses are "OK" or "ERROR x" where x might be -1 to -9.

3.2 Basic Commands

3.2.1 MODE <mode>

The MODE command will set the analyzer either to VNA or Bode mode. Possible arguments are: VNA or BODE.

3.2.2 MODE?

This query reads out the current TBVNA operation mode. Possible responses are VNA or BODE.

3.2.3 *RCL <filename>

This command will load a TBVNA setup file. Example *RCL 'new_setup'. Default Directory is the ./Setups directory of the analyzer. This command affects the status and, if an error occurs, resets it to -1.

3.2.4 LIMITS

This command reads out the result of a TBVNA limits evaluation. Please consult the TBVNA manual for more information. The command works as a query and will return either "PASS" or "FAIL" or "" if no measurement has been done yet.

3.3 Calibration subsystem

3.3.1 CAL:LOAD <filename>

This command loads a calibration file from the "./Calibrations" subdirectory. This command affects the status and will set it to -1 upon an error.

3.3.2 CAL:VALID?

This command returns the status of the current calibration. Possible return values are "YES" or "NO". Please be aware that changing start or stop frequencies during a valid calibration may render it invalid.

3.3.3 CAL:CLEAR

This command invalidates the current calibration.

3.3.4 CAL:DC_COMPENSATION

This command performs a TBVNA DC Calibration. This command must be executed to improve accuracy for measurements below 10 kHz.

3.3.5 CAL:EXTENSION:PORT1 <delay>,<loss>,<Z0>

This command lets you change the current calibration for Port 1 by adding a port extension. Delay is in ps, loss in GOhm/m and Z0 in Ohms.

3.3.6 CAL:EXTENSION:PORT2 <delay>,<loss>,<Z0>

This command lets you change the current calibration for Port 2 by adding a port extension. Delay is in ps, loss in GOhm/m and Z0 in Ohms.

3.3.7 CAL:EXTENSION:PORT1?

This query returns the current port 1 extension data in the format <delay(ps)>,<loss(GOhm/m)>,<Z0(Ohm)>

3.3.8 CAL:EXTENSION:PORT2?

This query returns the current port 2 extension data in the format <delay(ps)>,<loss(GOhm/m)>,<Z0(Ohm)>

3.4 Parameter System

3.4.1 PARAM:FREQ:START <freq in Hz> and PARAM:FREQ:START?

This command sets the start frequency of the sweep in Hz. The value can be floating point or integer. The Query returns the set value as floating point value. Please note, that this parameter serves no use in BODE mode.

3.4.2 PARAM:FREQ:STOP <freq in Hz> and PARAM:FREQ:STOP?

This command sets the stop frequency of the sweep in Hz. The value can be floating point or integer. The Query returns the set value as floating point value. Please note that this parameter serves no use in BODE mode.

3.4.3 PARAM:PWR and PARAM:PWR?

This command sets the port power of the sweep in dBm. The value can be floating point or integer. The Query returns the set value as floating point value. Please note that this parameter serves no use in BODE mode.

3.4.4 PARAM:POINTS and PARAM:POINTS?

This command sets the number of discrete measurement points. The value needs to be integer. The Query returns the set value as integer value. Please note that this parameter serves no use in BODE mode.

3.4.5 PARAM:SWEEP and PARAM:SWEEP?

This command sets the sweep Type. The value needs to be among LIN, LOG and TDR. The Query returns the set value. Please note that this parameter serves no use in BODE mode.

3.4.6 PARAM:BW <freq in Hz> and PARAM:BW?

This command sets the measurement bandwidth of the sweep in Hz. The value can be floating point or integer. The Query returns the set value as floating point value. Please note that this parameter serves no use in BODE mode.

3.4.7 PARAM:PORT1:ATT <value> and PARAM:PORT1:ATT?

This parameter configures the port attenuation of Port 1. The value must be either 0 for 0 dB or 20 for 20 dB. The query returns the configured value. Please note, that changing this value will invalidate the current calibration.

3.4.8 PARAM:PORT2:ATT <value> and PARAM:PORT2:ATT?

This parameter configures the port attenuation of Port 2. The value must be either 0 for 0 dB or 20 for 20 dB. The query returns the set value. Please note, that changing this value will invalidate the current calibration.

3.4.9 PARAM:AVERAGE <value> and PARAM:AVERAGE?

This parameter configures the averaging of the measured data. The value must be an unsigned integer between 0 and 2 to 100, where 0 means no averaging. The query returns the configured value.

3.5 The Memory subsystem

3.5.1 MEMORY:LOAD <nr>,<filename>

This command loads a touchstone S-Parameter file from the ./Data subdirectory. The status may be either OK or -1 for a loading error. The memory slot is selected by the <nr> parameter, which can be 1,2,3 or 4.

3.5.2 MEMORY:COPY <nr>

This command copies the current S-Parameter / Bode dataset to the memory with location <nr> in the range 1-4.

3.5.3 MEMORY:CLEAR <nr>

This command clears the selected memory slot <nr> in the range 1-4

3.5.4 MEMORY:VALID? <nr>

This command returns the validity status of a selected memory slot <nr> 1-4. YES, if there is valid data in the slot and NO, if there isn't.

3.6 Read Data Commands

3.6.1 READ:TRACE:SINGLE <diag_name>,<trace_name>,<x-value>

This command returns the y-value of a selected diagram and traces at a given x-value.

Parameters:

diag_name: Name of the selected diagram window using single quotes, like 'new diagram'.

trace_name: Name of the selected trace using single quotes, like 'new trace'.

x-value: floating point value of the x-axis, for example 1.0e6 for 1 MHz

Return Values:

x-value, y-value : for real values results

x-value, y-value-real, y-value-imaginary : for complex valued results.

This command sets the status variable, 0 for success, -1 for error. Errors include diagram and/or trace not found x-value out of range.

3.6.2 READ:TRACE <diag_name>,<trace_name>

This command returns all y-values of a selected diagram and trace.

Parameters:

diag_name: Name of the selected diagram window, using single quotes like 'new diagram'.

trace_name: Name of the selected trace, using single quotes like 'new trace'.

Return Values:

x-value, y-value, x-value2, y-value2..... : for real values results

x-value, y-value-real, y-value-imaginary, x-value2, y-value-real2, y-value-imaginary2..... : for complex valued results.

This command sets the status variable; 0 for success, -1 for error. Errors include diagram and/or trace not found, parameter count not match etc.

3.6.3 READ:MARKER <diag_name>,<trace_name>

This command returns x and y position of the selected marker.

Parameters:

diag_name: Name of the selected diagram window, using single quotes like 'new diagram'.

marker_name: Name of the selected marker, using single quotes like 'new marker'.

Return Values:

x-value, y-value: for real values results

x-value, y-value-real, y-value-imaginary, : for complex values results.

This command sets the status variable; 0 for success, -1 for error. Errors include diagram and/or marker not found, parameter count not match etc.

3.6.4 READ:SPAR:S11, READ:SPAR:S12, READ:SPAR:S21, READ:SPAR:S22

These commands reads the selected S-Parameter and outputs all data.

Return Format

frequency-value1, real-value1, imaginary-value1, frequency-value2, real-value2, imaginary-value2,
.....

3.6.5 READ:BODE:CHA, READ: BODE:CHB, READ: BODE:CH1, READ: BODE:CH2

These commands reads the selected Bode-Parameter and outputs all data.

Return Format

frequency-value1, real-value1, imaginary-value1, frequency-value2, real-value2, imaginary-value2,
.....

3.7 Marker Functions

3.7.1 MARKER:ADD <diag_name>,<trace_name>,<marker_name>

This function adds a marker to the selected diagram and trace.

Parameters:

diag_name: Name of the selected diagram window, using single quotes like 'new diagram'.

trace_name: Name of the selected trace, using single quotes like 'new trace'.

marker_name: Name of the created marker, using single quotes like 'new marker'.

3.7.2 MARKER:FUNC <diag_name>,<trace_name>,<marker_name>,<marker_function>,(<marker parameter>)

This command executes a marker function <marker_function> on the selected marker.

diag_name: Name of the selected diagram window, using single quotes like 'new diagram'.

trace_name: Name of the selected trace, using single quotes like 'new trace'.

marker_name: Name of the selected marker, using single quotes like 'new marker'.

marker_parameter: Optional parameter used by some marker functions.

marker_function: name of the selected function without quotes, which are:

MAX : find marker maximum

MIN : find marker minimum

PEAK_RIGHT : Find next peak right to current position

VALLEY_RIGHT : Find next valley right to current position

PEAK_LEFT : Find next peak left to current position

VALLEY_LEFT : Find next valley left to current position

NPEAK_RIGHT : Find next negative peak right to current position

NPEAK_LEFT : Find next negative peak left to current position

MARKER_TO_CENTER: Move marker to the center of the diagram (in terms of x-values)

DELETE: Delete the marker

MARKER_TO_X: Move marker to the x-position, given in the optional parameter

FIND_Y : Find the given Y-Value (in optional parameter) and move marker there.

TRACK_Y: Enable Y-value tracking. The optional parameter can be among ON or OFF

TRACK_MAX: Enable maximum-value tracking. The optional parameter can be among ON or OFF

TRACK_MIN: Enable minimum-value tracking. The optional parameter can be among ON or OFF

FIND_Y_RIGHT : Find the next given Y-Value (in optional parameter) right from current position and move marker there.

FIND_Y_LEFT : Find the next given Y-Value (in optional parameter) left from current position and move marker there.